



TIMBERTECH CLASSIC COMPOSITE SERIES AND RESERVE RAILING INSTALL GUIDE

Installing TimberTech Railing with Balusters	3
Installing TimberTech Stair Railing with Balusters	9
Installing TimberTech Railing with CableRail by Feeney®	13
Installing TimberTech Stair Railing with CableRail by Feeney®	22
Installing TimberTech Railing with Glass Infill	30
Installing TimberTech Stair Railing with Glass Infill	38
Installing TimberTech Reserve Rail Over the Post	43
Notes	51

TimberTech Reserve Rail can be installed with a continuous Top Rail in up to 16' lengths, measured from the center of the end posts. These applications require the use of a 4" Post Sleeve, 4" Post Skirt and a 4" x4" Post as an intermediate post, as well as unique fastening procedures. This Install Guide details these unique procedures.

IMPORTANT NOTES:

- Please read all instructions completely before starting any part of the installation. Always make sure to visit www.TimberTech.com to ensure you are viewing the most current installation instructions, care and cleaning, technical information and more.
- TimberTech Railing should be installed using the same good building principles used to install wood or composite railing and in accordance with the local building codes and the installation guidelines included below.
- AZEK Co. LLC accepts no liability or responsibility for the improper installation of this product.
- TimberTech Railing may not be suitable for every application and it is the sole responsibility of the installer to be sure that TimberTech Railing is fit for the intended use. Since all installations are unique, it is also the installer's responsibility to determine specific requirements in regards to each Rail application.
- AZEK Co. LLC recommends that all applications be reviewed by a licensed architect, engineer or local building official before installation. If you have any questions or need further assistance, please call AZEK Customer Service at 877-ASK-AZEK (877-275-2935) or visit our website at www.TimberTech.com.
- TimberTech Railing is tested as a whole system and should be used that way. It is not intended to be used in conjunction with other railing systems or fasteners.
- The following Installation Guidelines are applicable for installation of TimberTech Classic Composite Series and TimberTech Reserve Rail Systems.
- **IMPORTANT:** Make sure the DRIVE TOOL/DRILL is configured or set to use the SCREW setting when driving and/or tightening all FASTENERS. It is very Important not to overdrive fasteners. The use of Impact type drill drivers can increase the risk of overdriving fasteners.
- **SAFETY:** Always wear goggles when handling, cutting, drilling and fastening materials.
- Failure to install this product in accordance with applicable building codes and TimberTech's written Railing Install Guide may lead to personal injury, affect rail system performance and void the product warranty.
- The buildup or generation of static electricity is a naturally occurring phenomenon in many plastic based products such as carpeting, upholstery, and clothing, and can occur on alternative decking under certain environmental conditions. This static electricity can discharge once contact is made with hardware, railing, or other conductors of electricity.



Find install videos, written instructions and a chat link at <https://www.timbertech.com/installation-help>.

NOTE: IF INSTALLING POST LIGHTING, WIRING MUST BE INSTALLED PRIOR TO SECURING POSTS TO DECK/STAIR SURFACE AND INSTALLING TOP RAILS.

It is the responsibility of the installer to meet all local code requirements and obtain all required building permits. The installer should determine and implement appropriate installation techniques for each installation situation. The AZEK Company or its reseller shall not be held responsible for improper or unsafe installations.

INSTALLING RAILING WITH BALUSTERS

FOR CLASSIC COMPOSITE SERIES AND RESERVE RAIL

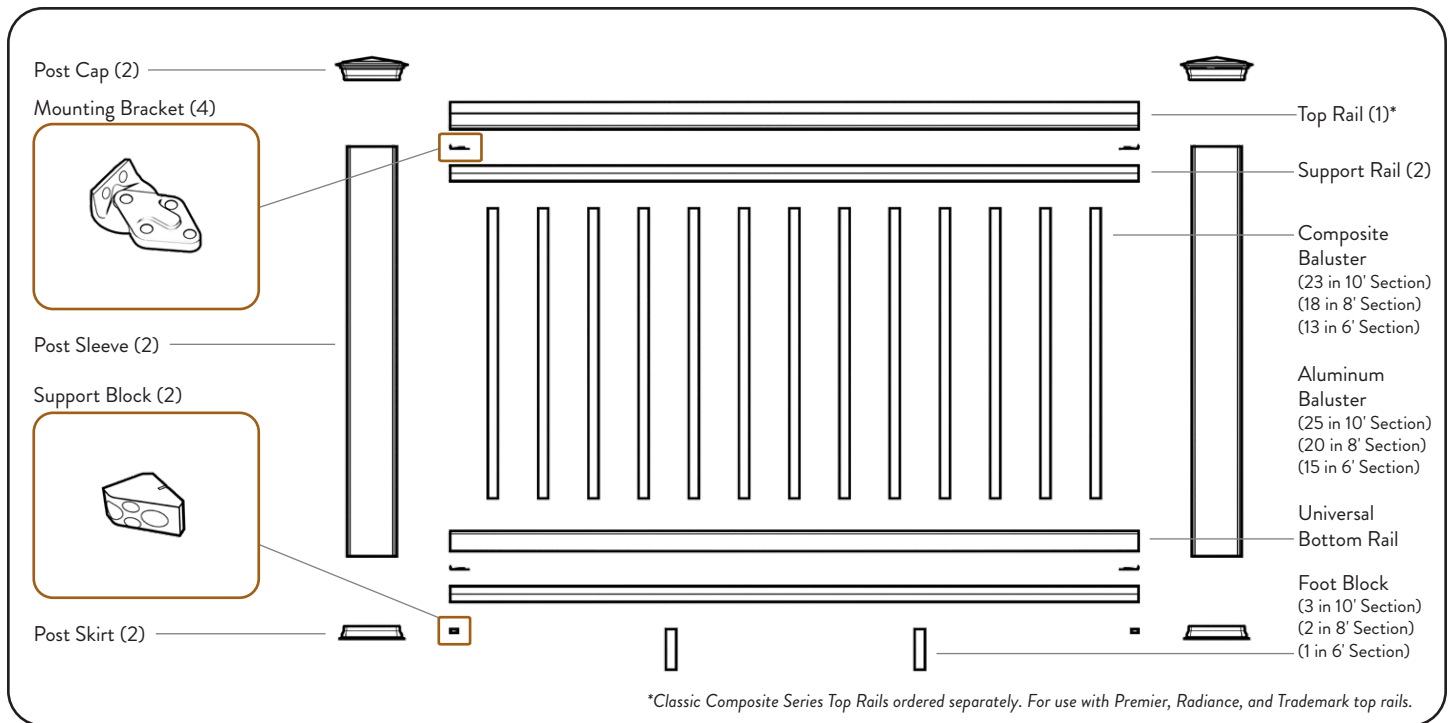

! This entire section of instructions is for installation of Classic Composite Series and Reserve Rail systems. Installation of the RESERVE RAIL system is identical to the Classic Composite Series, except it uses the RESERVE BOTTOM RAIL instead of the Universal Bottom Rail.

! IMPORTANT NOTES:

- **Prior to construction, check with your local regulatory agency for special code requirements in your area.**
- Common railing height is 36" or 42".
- TimberTech Railing 10', 8' and 6' Rails are designed not to exceed 10', 8' and 6' from center of post to center of post, respectively.
- For all other applications, consult a design professional or a TimberTech Railing representative for more information.
- For all stair applications, maximum rail length must not exceed 91".
- If using anything other than aluminum support rail, the maximum rail length must not exceed 91".
- 4x4 lumber posts must be installed plumb and level with each other.
- Cut slowly, using a thin kerf, finish saw blade to avoid chipping.
- Read instructions completely to get an understanding of how the product goes together and how each piece affects the other.
- For all applications, a structural post must be used inside our Post Sleeve.
- Compatible with all Classic Composite Series Railing Infills.

! IMPORTANT NOTES:

- Visit <https://www.timbertech.com/installation-help> to view TimberTech installation videos.
- Consult your local building codes for guard and handrail requirements.
- TimberTech Railing 10', 8' and 6' Rails are designed not to exceed 10', 8' and 6' from center of post to center of post, respectively.
- For all other applications, consult a design professional or a TimberTech Railing representative for more information. For stair applications maximum rail length must not exceed 91".
- 4x4 lumber posts must be installed plumb and level with each other.
- Cut slowly, using a thin kerf, finish saw blade to avoid chipping.
- Read instructions completely to get an understanding of how the product goes together and how each piece affects the other.
- For all applications, a structural post must be used inside our Post Sleeve.
- Compatible with all Classic Composite Series Railing Infills.

TOOLS REQUIRED

- Miter Saw
- 7/64" Drill Bit
- Measuring Tape
- Drill
- 3/16" Drill Bit
- Caulk Gun

COMPONENTS NEEDED FOR INSTALLING ONE TIMBERTECH RAIL SECTION

(TOP RAIL NOT INCLUDED IN CLASSIC COMPOSITE SERIES)

Components needed to complete install of 10', 8', and 6' rail sections One Kit = One Rail Pack + One Baluster Pack + One Baluster Screw Kit. Kits only available in 36" height.	1 - Top Rail 1 - Universal Bottom Rail 2 - Support Rails (1 - Aluminum Top Support Rail for 10') Foot Blocks - 1 in 6' Kits, - 2 in 8' Kits, - 8 in 10' Kits, Composite Balusters - 13 in 6' Kits, - 18 in 8' Kits, - 23 in 10' Kits Hardware Mounting Kit Support Block Mounting Templates Baluster Screw Kit						
Components available separately for mix-and-match rail systems	<table border="1" style="width: 100%; border-collapse: collapse;"> <tr> <td style="width: 50%; text-align: center; vertical-align: middle;">TimberTech Rail Pack</td> <td style="vertical-align: top;"> (Top Rails sold separately) 1 - Universal Bottom Rail (with Classic Composite Series) 2 - Support Rails (1 - Aluminum Top Support Rail for 10') Hardware Mounting Kit Support Block Mounting Templates Foot Blocks - 1 in 6' Packs, - 2 in 8' Packs, - 3 in 10' Packs </td> </tr> <tr> <td style="text-align: center; vertical-align: middle;">Baluster Pack</td> <td style="vertical-align: top;"> <table border="0" style="width: 100%;"> <tr> <td style="width: 50%; vertical-align: top;"> Composite Balusters - 18 Balusters per Pack (23 required per 10' section) (18 required per 8' section) (13 required per 6' section) - 29" for 36" Railing - 31" for 36" Railing (with less than 2" gap between deck & Bottom Rail) - 35" for 42" Railing - 37" for 42" Railing (with less than 2" gap between deck & Bottom Rail) </td> <td style="width: 50%; vertical-align: top;"> Aluminum Balusters - 20 Balusters per Pack (25 required per 10' section) (20 required per 8' section) (15 required per 6' section) - 29" for 36" Railing (with less than 2" gap between deck & Bottom Rail) - 35" for 42" Railing - 37" for 42" Railing (with less than 2" gap between deck & Bottom Rail) </td> </tr> </table> </td> </tr> </table>	TimberTech Rail Pack	(Top Rails sold separately) 1 - Universal Bottom Rail (with Classic Composite Series) 2 - Support Rails (1 - Aluminum Top Support Rail for 10') Hardware Mounting Kit Support Block Mounting Templates Foot Blocks - 1 in 6' Packs, - 2 in 8' Packs, - 3 in 10' Packs	Baluster Pack	<table border="0" style="width: 100%;"> <tr> <td style="width: 50%; vertical-align: top;"> Composite Balusters - 18 Balusters per Pack (23 required per 10' section) (18 required per 8' section) (13 required per 6' section) - 29" for 36" Railing - 31" for 36" Railing (with less than 2" gap between deck & Bottom Rail) - 35" for 42" Railing - 37" for 42" Railing (with less than 2" gap between deck & Bottom Rail) </td> <td style="width: 50%; vertical-align: top;"> Aluminum Balusters - 20 Balusters per Pack (25 required per 10' section) (20 required per 8' section) (15 required per 6' section) - 29" for 36" Railing (with less than 2" gap between deck & Bottom Rail) - 35" for 42" Railing - 37" for 42" Railing (with less than 2" gap between deck & Bottom Rail) </td> </tr> </table>	Composite Balusters - 18 Balusters per Pack (23 required per 10' section) (18 required per 8' section) (13 required per 6' section) - 29" for 36" Railing - 31" for 36" Railing (with less than 2" gap between deck & Bottom Rail) - 35" for 42" Railing - 37" for 42" Railing (with less than 2" gap between deck & Bottom Rail)	Aluminum Balusters - 20 Balusters per Pack (25 required per 10' section) (20 required per 8' section) (15 required per 6' section) - 29" for 36" Railing (with less than 2" gap between deck & Bottom Rail) - 35" for 42" Railing - 37" for 42" Railing (with less than 2" gap between deck & Bottom Rail)
TimberTech Rail Pack	(Top Rails sold separately) 1 - Universal Bottom Rail (with Classic Composite Series) 2 - Support Rails (1 - Aluminum Top Support Rail for 10') Hardware Mounting Kit Support Block Mounting Templates Foot Blocks - 1 in 6' Packs, - 2 in 8' Packs, - 3 in 10' Packs						
Baluster Pack	<table border="0" style="width: 100%;"> <tr> <td style="width: 50%; vertical-align: top;"> Composite Balusters - 18 Balusters per Pack (23 required per 10' section) (18 required per 8' section) (13 required per 6' section) - 29" for 36" Railing - 31" for 36" Railing (with less than 2" gap between deck & Bottom Rail) - 35" for 42" Railing - 37" for 42" Railing (with less than 2" gap between deck & Bottom Rail) </td> <td style="width: 50%; vertical-align: top;"> Aluminum Balusters - 20 Balusters per Pack (25 required per 10' section) (20 required per 8' section) (15 required per 6' section) - 29" for 36" Railing (with less than 2" gap between deck & Bottom Rail) - 35" for 42" Railing - 37" for 42" Railing (with less than 2" gap between deck & Bottom Rail) </td> </tr> </table>	Composite Balusters - 18 Balusters per Pack (23 required per 10' section) (18 required per 8' section) (13 required per 6' section) - 29" for 36" Railing - 31" for 36" Railing (with less than 2" gap between deck & Bottom Rail) - 35" for 42" Railing - 37" for 42" Railing (with less than 2" gap between deck & Bottom Rail)	Aluminum Balusters - 20 Balusters per Pack (25 required per 10' section) (20 required per 8' section) (15 required per 6' section) - 29" for 36" Railing (with less than 2" gap between deck & Bottom Rail) - 35" for 42" Railing - 37" for 42" Railing (with less than 2" gap between deck & Bottom Rail)				
Composite Balusters - 18 Balusters per Pack (23 required per 10' section) (18 required per 8' section) (13 required per 6' section) - 29" for 36" Railing - 31" for 36" Railing (with less than 2" gap between deck & Bottom Rail) - 35" for 42" Railing - 37" for 42" Railing (with less than 2" gap between deck & Bottom Rail)	Aluminum Balusters - 20 Balusters per Pack (25 required per 10' section) (20 required per 8' section) (15 required per 6' section) - 29" for 36" Railing (with less than 2" gap between deck & Bottom Rail) - 35" for 42" Railing - 37" for 42" Railing (with less than 2" gap between deck & Bottom Rail)						
Hardware included in Hardware Mounting Kits:	4 - Mounting Brackets 2 - Support Blocks 16 - #8 x 3/4" Screws 6 - #8 x 1 5/8" Screws 6 - #8 x 2 5/8" Screws (Stairs Only) 6 - #8 x 3" Screws 12 - #8 x 3" Semi-threaded Screws T20 Driver Bit						
Additional Components Needed for Each System	2 - Post Caps 2 - Post Sleeves 2 - Post Skirts						

COMPONENT DIMENSIONS

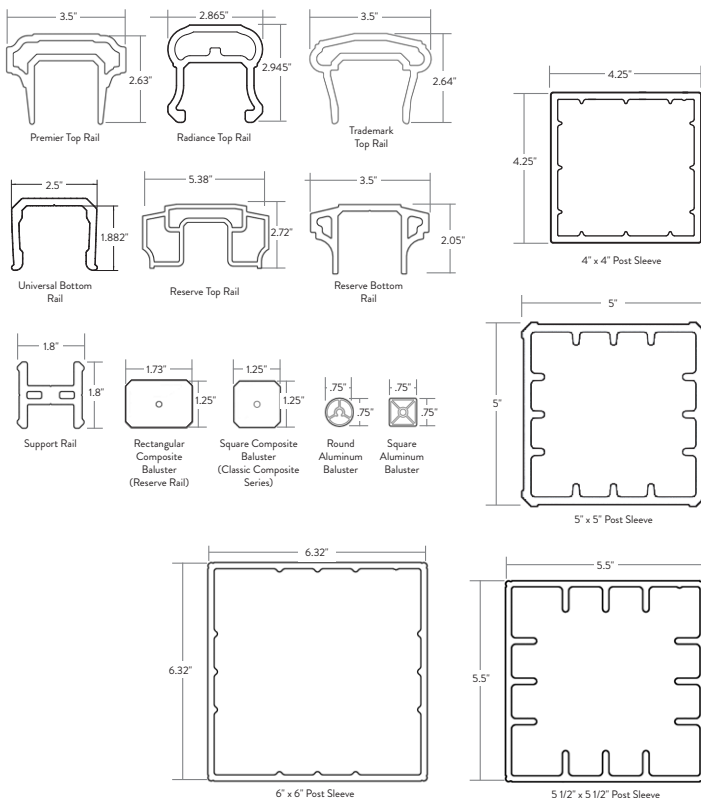

MEASURING YOUR RAILING AREA

- Measurements are from center to center of the posts. Rails are produced in 10', 8' and 6' to allow for finished end cuts and angles.
- Determine how many 10', 8' and 6' TimberTech Rail Sections you need and check to be sure you have all the components (and quantities) listed in the chart shown.

INSTALLING RAILING WITH BALUSTERS

FOR CLASSIC COMPOSITE SERIES AND RESERVE RAIL



1

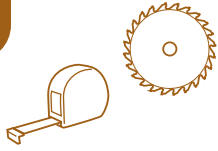

INSTALL POST SLEEVES

- Trim Post Sleeves to desired length.
- Slide Post Sleeves and Post Skirt over post (do not force). Post sleeve will be slightly larger than the post.
- Ensure posts are square and plumb. Shim as needed to plumb.

IMPORTANT NOTES:

Be sure to cut Post Sleeves such that finished rail height is at least 36" high for a 36" rail application and 42" high for a 42" application.

For all rail installations, post and post covers must be plumb and aligned with one another.

For Over-the-Post applications, it is critical that Posts be of a consistent height (e.g. the tops of all post sleeves are level and on plane with each other).

TIP: To ensure that the tops of all post sleeves are level, you may use a traditional 8 ft. level or a string line to establish a common level across all post sleeves and cut at that level. Alternatively, you may use a laser level to "shoot" a level mark on each post sleeve and then cut at that mark.

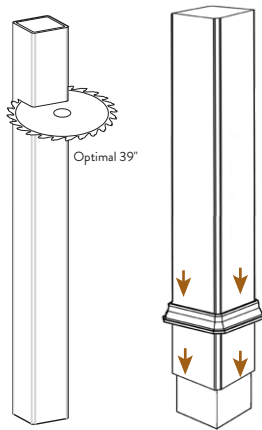

39" above deck surface is optimal for 36" railing heights.

2

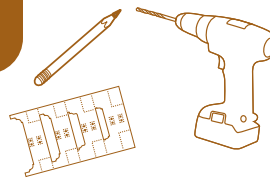

INSTALL LOWER SUPPORT BLOCKS

- Position template at bottom of Post Sleeve above Post Skirt.

If you do not have the template, position the top of the Support Block 4" above the deck.

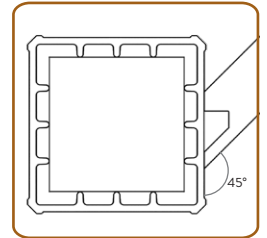

For angled rail installations, align angled face of Support Block parallel to rail section.

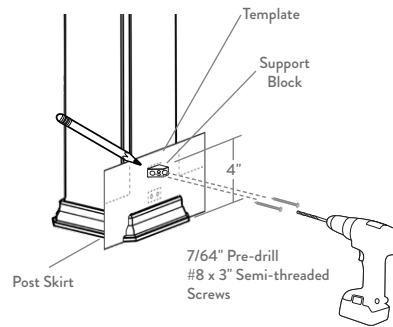

3

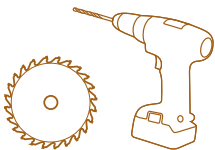

CUT AND ASSEMBLE BOTTOM SUPPORT RAIL

- Cut the Bottom Support Rail to length.
- Add support blocks as required.
- Attach brackets.

! For sections up to 6': Place one Foot Block in the center of the rail.

For sections 6' to 8': Space two Foot Blocks approximately at 1/3 intervals on the rail.

For sections 8' to 10': Space three Foot Blocks approximately at 1/4 intervals on the rail.

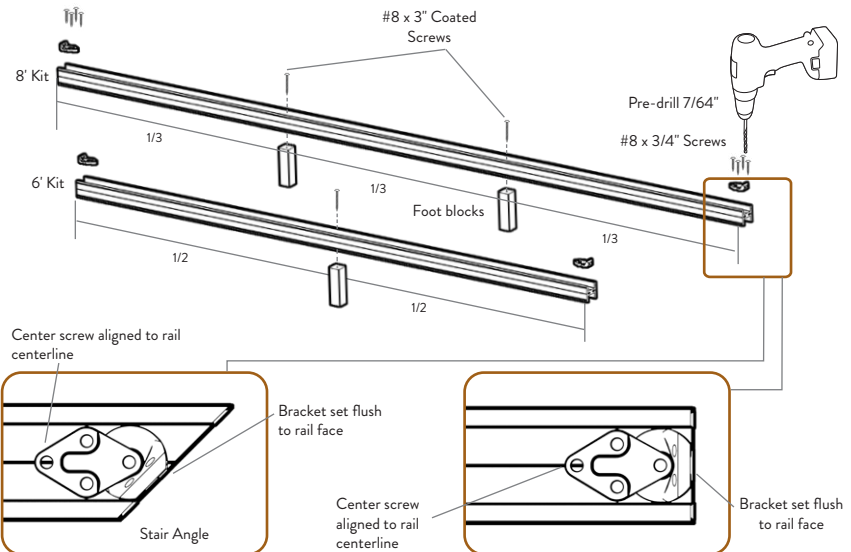

4



INSTALL BOTTOM SUPPORT RAIL

- Position Bottom Support Rail assembly onto Support Blocks.
- Pre-drill holes into post sleeves only.
- Attach brackets with green coated screws.

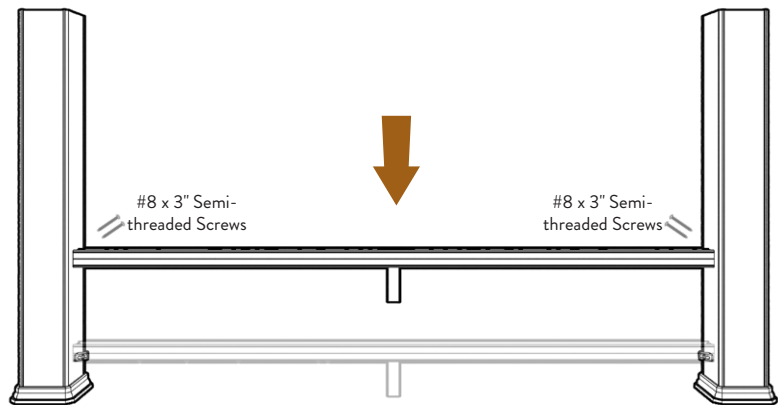
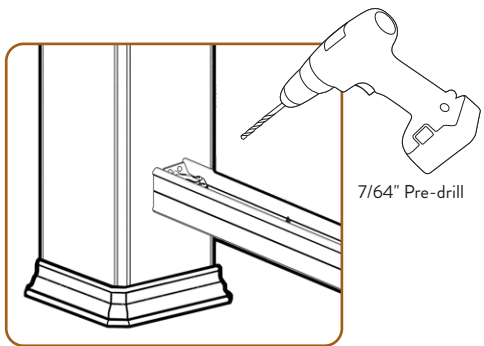

5

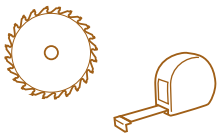

SPACE BALUSTER AND TRIM RAILS

- Measure distance between the posts at the Bottom Support Rail.
- Transfer measurement to Universal Bottom Rail. To prevent end balusters from interfering with the post sleeves, center either on a pre-drilled hole, or between two pre-drilled holes (see diagram below).
- Cut Universal Bottom Rail and Top Support Rail to length.



The space between the end baluster and post can not exceed 4"

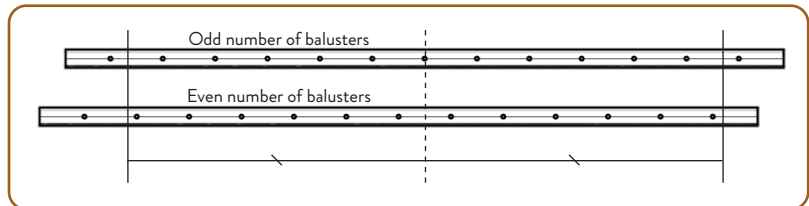

Important: cut the same amount from each side to ensure the balusters are spaced evenly on the ends.

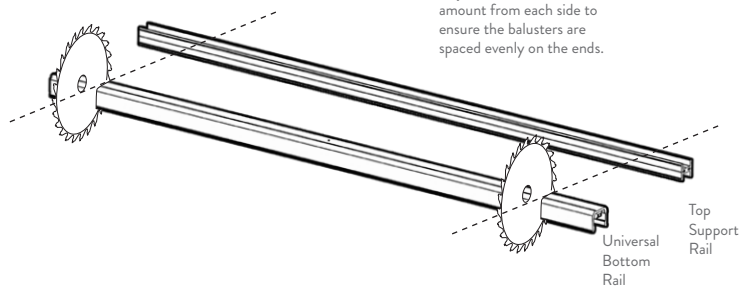

INSTALLING RAILING WITH BALUSTERS

FOR CLASSIC COMPOSITE SERIES AND RESERVE RAIL



6

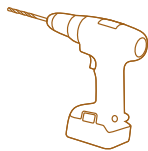

ASSEMBLE BALUSTER SECTION

- Attach Mounting Brackets at each end of the Top Support Rail (outlined in Step 3).
- Attach balusters using pre-drilled holes starting with the support rail and then the Universal Bottom Rail.



For 10' rail sections utilizing aluminum support rail, when attaching Mounting Brackets at each end of the Top Support Rail, pre-drill using a 9/64" drill bit (instead of 7/64" bit).

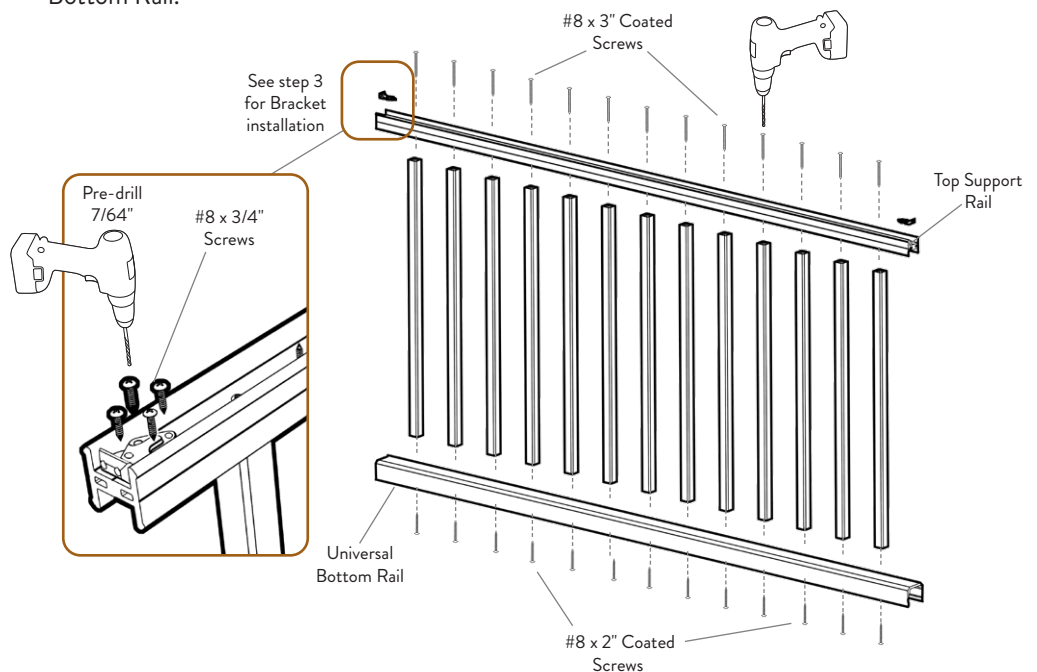

7

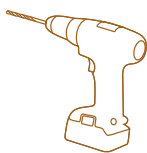

INSTALL RAIL ASSEMBLY

- Place finished section on Bottom Support Rail.
- Align Top Support Rail to center of Posts.
- Attach brackets on Top Support Rail to posts.



NOTE: If installing a Deck Board as a Top Rail, please refer to Deck Rail Install Guide.

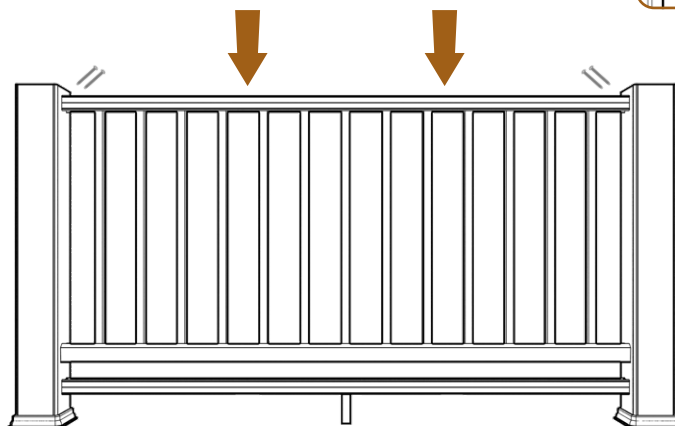
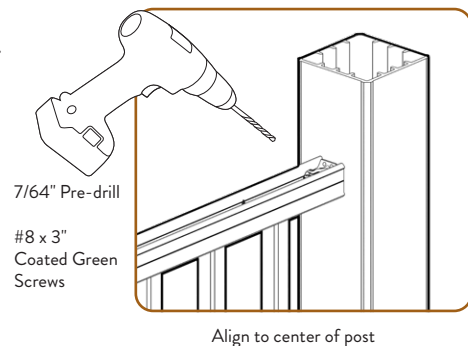

8

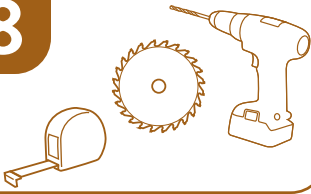

INSTALL TOP RAIL AND POST CAPS

- Measure and cut Top Rail (not included) to length. Trim both ends for a clean cut. If installing Deck board as Drink Rail, please refer to Drink Rail Install Guide
- **Important:** Pre-drill 3/16" holes through the top support rail as illustrated below.
- Attach Top Rail using 1 5/8" screws, driving screws up through bottom of support rail into Top Rail.
- Attach Post caps using exterior grade caulk applied to the underside of the cap.

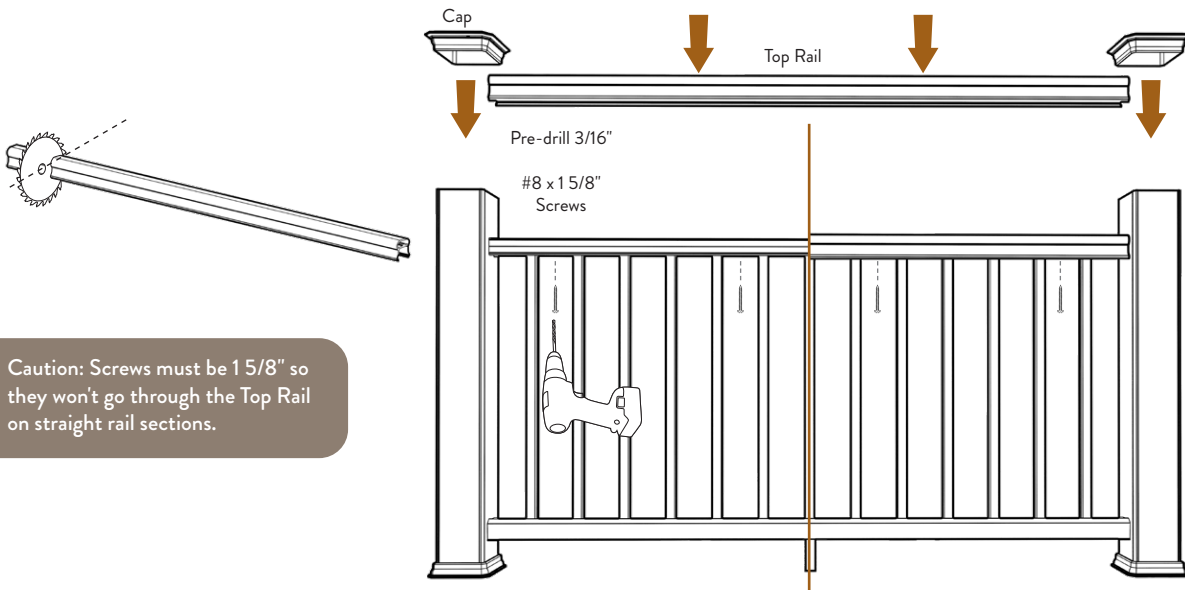

INSTALLING STAIR RAILING WITH BALUSTERS

FOR CLASSIC COMPOSITE SERIES AND RESERVE RAIL



1

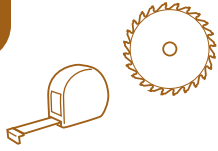

INSTALL POST SLEEVES

- Trim Post Sleeves to desired length.
- Slide Post Sleeves and Post Skirt over post (do not force). Post sleeve will be slightly larger than the post.
- Ensure posts are square and plumb. Shim to plumb as needed.

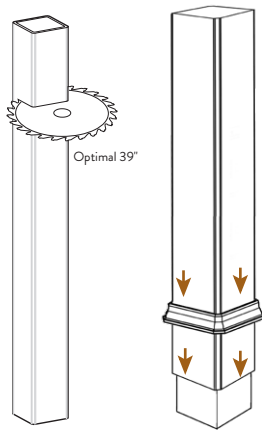

IMPORTANT NOTES:

Be sure to cut Post Sleeves such that finished rail height is at least 36" high for a 36" rail application and 42" high for a 42" application.

For all rail installations, post and post covers must be plumb and aligned with one another.

For Over-the-Post applications, it is critical that Posts be of a consistent height (e.g. the tops of all post sleeves are level and on plane with each other).

2

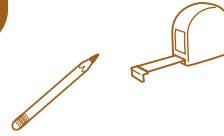

MEASURE SUPPORT RAILS

- Determine measurements and angle as shown.
- Trim both the Top Support Rail and the Bottom Support Rail to those dimensions.
- Test fit rails to check for accuracy.

Support Rails are rotated 90° for stair rail applications.

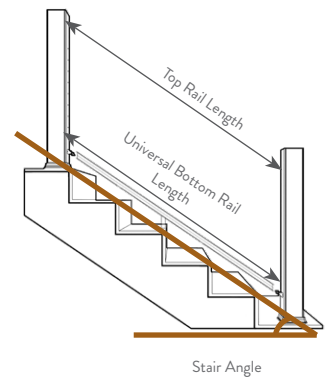
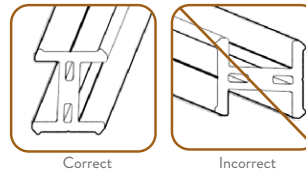

3

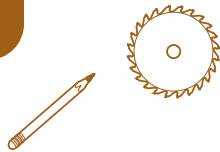

TRIM RAILS

- Transfer measurement from Bottom Support Rail to Universal Bottom Rail.
- Trim Top Rail to match Top Support Rail at appropriate angle.

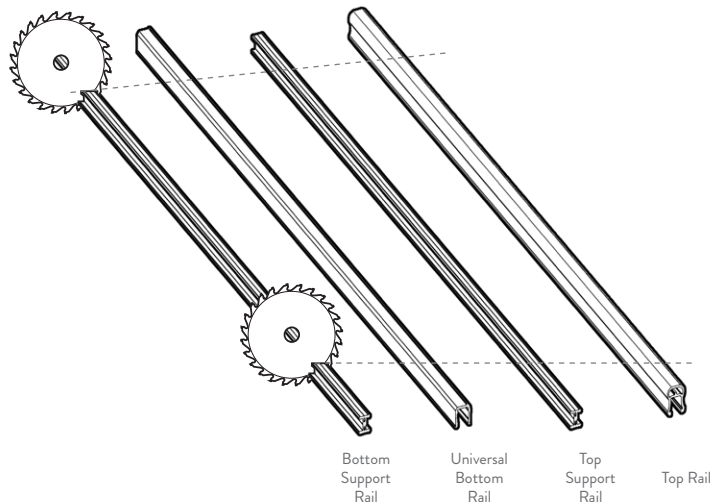

This entire section of instructions is for installation of Classic Composite Series and Reserve Rail systems. Installation of the RESERVE RAIL system is identical to the Classic Composite Series, except it uses the RESERVE BOTTOM RAIL instead of the Universal Bottom Rail.

4

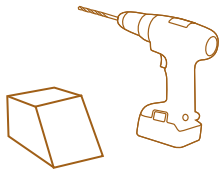

DRILL BALUSTER HOLES

- Place the Universal Bottom Rail and the Top Support Rail together as shown to keep the holes aligned.

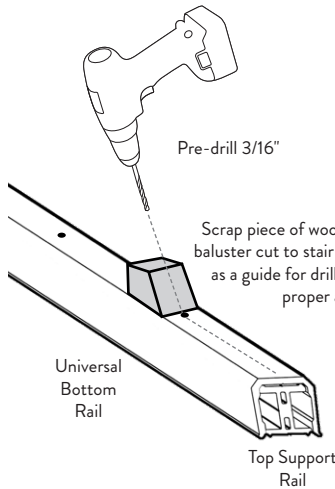

5

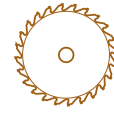

TRIM BALUSTERS

Trim Baluster ends to required angle as shown.

Important: Start cut at top edge to maximize the length.

Aluminum stair Balusters are precut to a stair angle and are not to be cut on the job site.

- Trim TOP of Foot Block to stair angle as well.

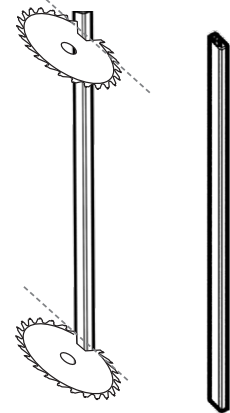

6



ASSEMBLE BALUSTERS

- Attach Balusters to Top and Bottom Support Rails and attach Brackets to Top Support Rail.

! Tip for Universal Bottom Rail: Partially drive screws into all Balusters before driving them in completely.

! Brackets must be on the side of the rail facing the stairs.

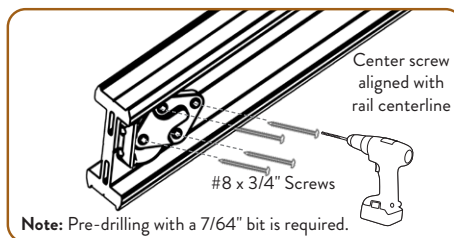
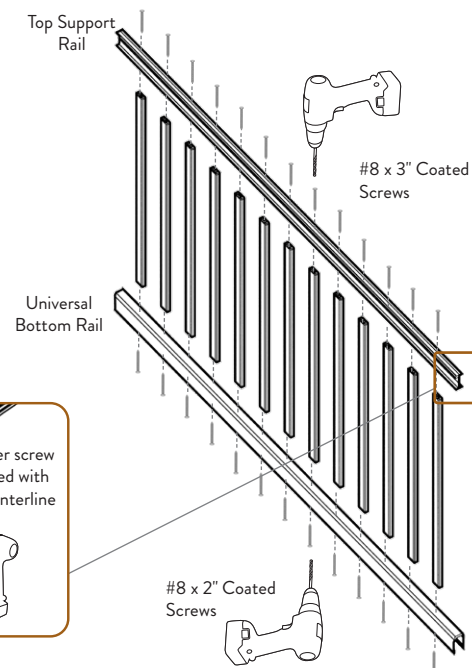

INSTALLING STAIR RAILING WITH BALUSTERS

FOR CLASSIC COMPOSITE SERIES AND RESERVE RAIL



7

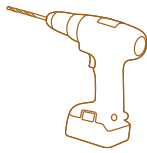

INSTALL BOTTOM SUPPORT RAIL

- Attach Mounting Brackets to Bottom Support Rail.
- Secure Mounting Brackets to posts.
- Wedge Foot Block under Support Rail & Attach.



Brackets must be installed to the stair tread side of the rail.

For sections up to 6': Place one Foot Block in the center of the rail.

For sections 6' to 8': Space two Foot Blocks approximately at 1/3 intervals on the rail.

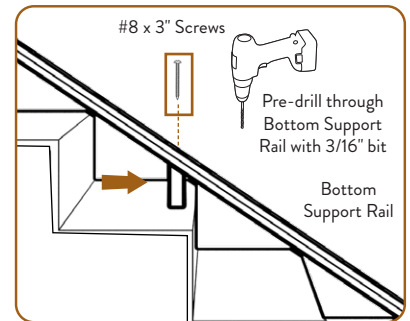
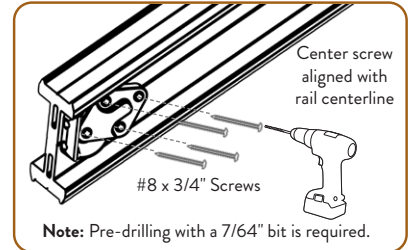
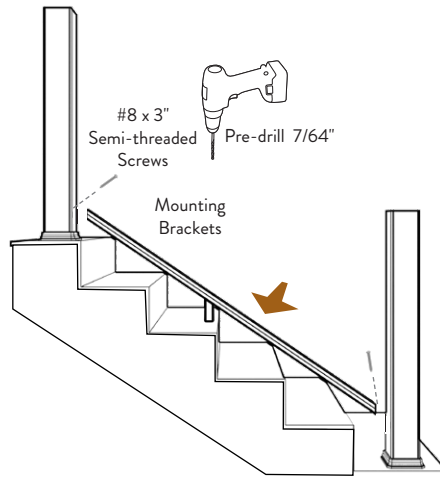

8

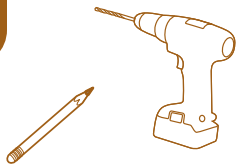

INSTALL RAIL ASSEMBLY

- Mark ends of support rail for position of support block.
- Rotate Rail assembly out of way to fasten Support Block.
- Secure Mounting Brackets to Posts.

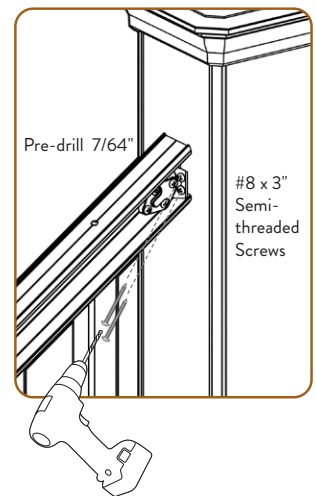
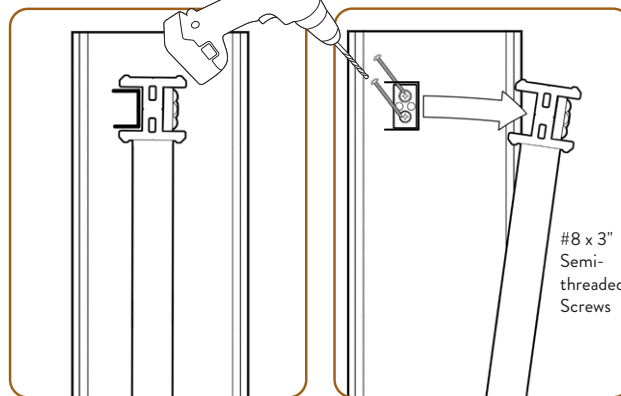
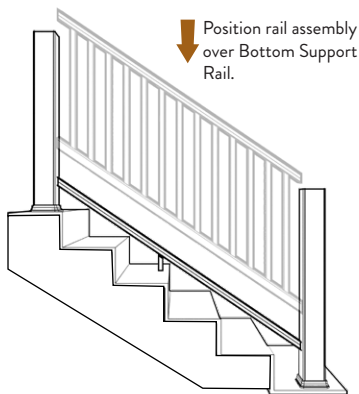

NOTE: If installing a Deck Board as a Top Rail, please refer to Deck Rail Install Guide.

9



INSTALL TOP RAIL AND POST CAPS

- If installing Deck board as Drink Rail, please refer to Drink Rail Install Guide
- Attach Top Rail using 2 5/8" screws, driving screws up through bottom of support rail into Top Rail.
- Attach Post caps using exterior grade caulk applied to the underside of the cap.



For typical stair angles, use provided 2 5/8" Screws to fasten the Top Rail.

Note: Pre-drilling with a 3/16" bit is required.

#8 x 2 5/8"
Coated Screws

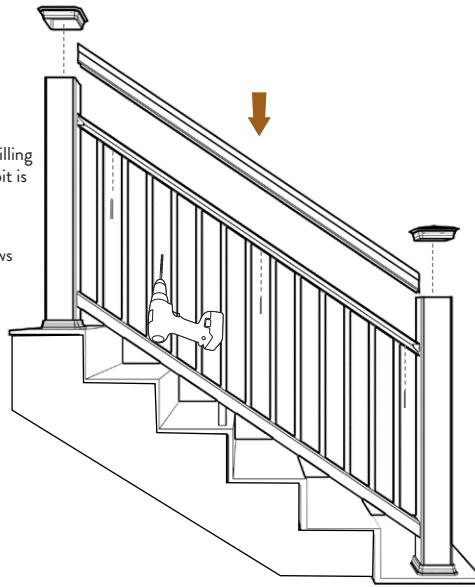

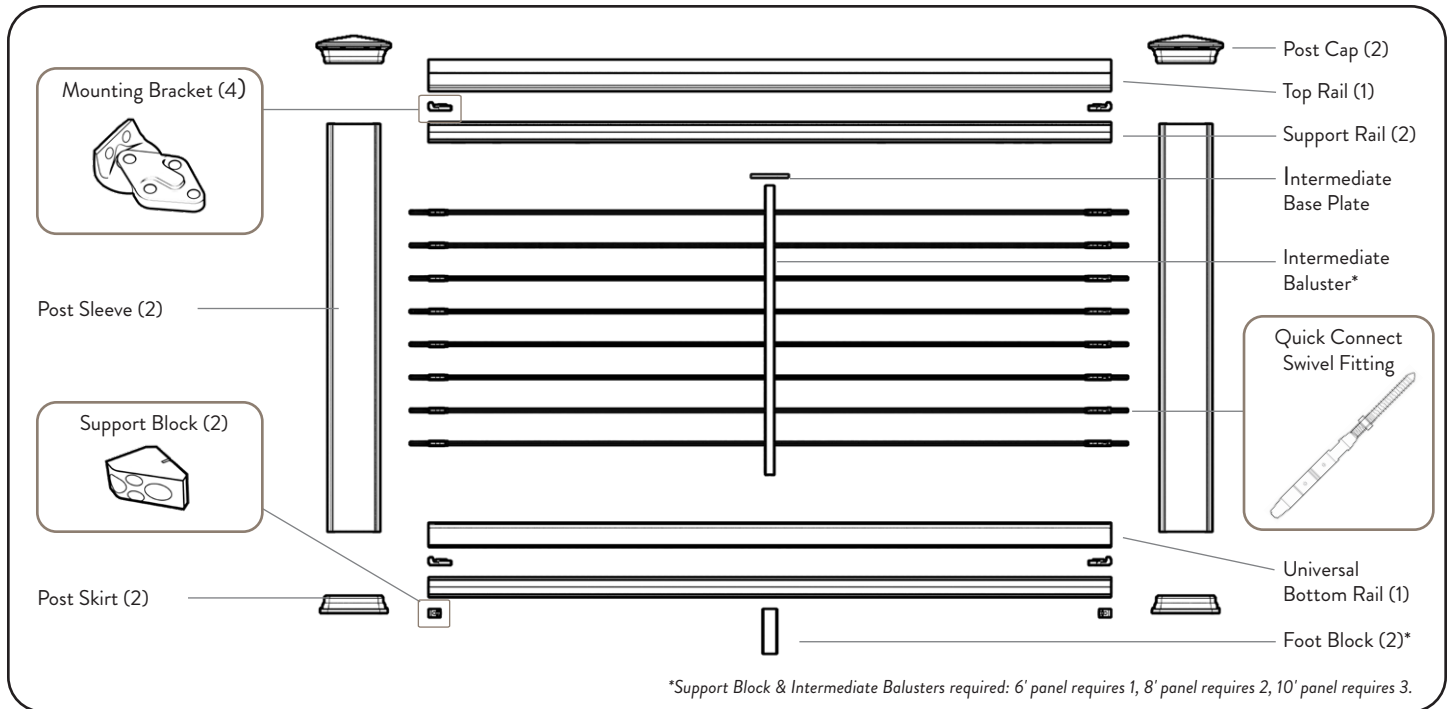

⚠️ IMPORTANT NOTES:

- TimberTech Custom Rail Packs are available in 10', 8' and 6' lengths.
- Visit <https://www.timbertech.com/installation-help> to view TimberTech installation videos.
- Consult your local building codes for guard and handrail requirements.
- TimberTech Railing 10', 8' and 6' Rails are designed not to exceed 10', 8' and 6' from center of post to center of post, respectively.
- For all other applications, consult a design professional or a TimberTech Railing representative for more information. For stair applications maximum rail length must not exceed 91".
- 4x4 lumber posts must be installed plumb and level with each other.
- Cable rail is not compatible with secure mount post.
- Cut slowly, using a thin kerf, finish saw blade to avoid chipping.
- Read instructions completely to get an understanding of how the product goes together and how each piece affects the other.
- For all applications, a structural post must be used inside our Post Sleeve.
- Compatible with all Classic Composite Series Railing Infills.



This entire section of instructions is for installation of Classic Composite Series and Reserve Rail systems. Installation of the RESERVE RAIL system is identical to the Classic Composite Series, except it uses the RESERVE BOTTOM RAIL instead of the Universal Bottom Rail.

TOOLS REQUIRED

- Miter Saw
- Tape Measure
- Drill
- Cable Cutters
- #2 Square Drive
- Drill Bits: 7/64", 1/4", 3/16", 1/8"
- Extended 1/4" Drill Bit
- 2 3/8" Open-End Wrenches

MEASURING YOUR RAILING AREA

- Measurements are from center to center of the posts. Rail components are produced in 10', 8' and 6' to allow for finished end cuts and angles.
- Determine how many 10', 8' and 6' TimberTech Rail Sections you need and check to be sure you have all the components (and quantities) listed in the chart shown.

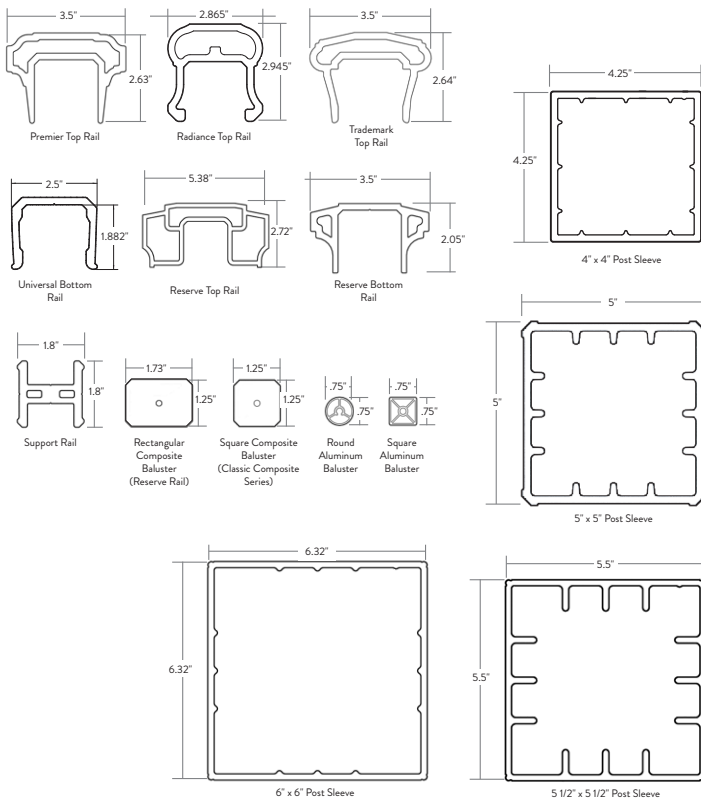
COMPONENT DIMENSIONS

COMPONENTS NEEDED FOR INSTALLING ONE TIMBERTECH RAIL SECTION

Components needed to complete install of 10', 8', and 6' rail sections One Kit = One Rail Pack + One Baluster Pack + One Baluster Screw Kit. Kits only available in 36" height.	Hardware Mounting Kit 4 - Mounting Brackets 2 - Support Blocks (6' panel requires 1, 8' panel requires 2, 10' panel requires 3) 16 - #8 x 3/4" screws 6 - #8 x 1 5/8" Screws 6 - #8 x 2 5/8" screws (Stairs Only) 6 - #8 x 3" Screws 12 - #8 x 3" Semi-threaded Screws T20 Driver Bit			
Components available separately for mix-and-match rail systems	TimberTech Rail Custom Rail Pack	(Top Rails sold separately) 1 - Universal Bottom Rail (with Classic Composite Series) 2 - Support Rails (1-Aluminum Top Support Rail for 10') Hardware Mounting Kit Support Block Mounting Templates Foot Blocks - 1 in 6' Packs, - 2 in 8' Packs, - 3 in 10' Packs		
Additional Components Needed for Each System	CableRail Components	<table border="0"> <tr> <td> 36" Intermediate Baluster - 1 for 6', 2 for 8', 3 for 10' 42" Intermediate baluster - 1 for 6', 2 for 8', 3 for 10' Stair Intermediate baluster - 1 for 6', 2 for 8', 3 for 10' Cable - 100' spool or 500' spool </td> <td> 36" Hardware Kit - 9 Quick-Connect Fittings - 9 Quick-Connect Swivel Fittings - 18 Hanger Bolts - 9 lock nuts 42" Hardware Kit - 9 Quick-Connect Fittings - 9 Quick-Connect Swivel Fittings - 22 Hanger Bolts - 11 lock nuts </td> </tr> </table>	36" Intermediate Baluster - 1 for 6', 2 for 8', 3 for 10' 42" Intermediate baluster - 1 for 6', 2 for 8', 3 for 10' Stair Intermediate baluster - 1 for 6', 2 for 8', 3 for 10' Cable - 100' spool or 500' spool	36" Hardware Kit - 9 Quick-Connect Fittings - 9 Quick-Connect Swivel Fittings - 18 Hanger Bolts - 9 lock nuts 42" Hardware Kit - 9 Quick-Connect Fittings - 9 Quick-Connect Swivel Fittings - 22 Hanger Bolts - 11 lock nuts
36" Intermediate Baluster - 1 for 6', 2 for 8', 3 for 10' 42" Intermediate baluster - 1 for 6', 2 for 8', 3 for 10' Stair Intermediate baluster - 1 for 6', 2 for 8', 3 for 10' Cable - 100' spool or 500' spool	36" Hardware Kit - 9 Quick-Connect Fittings - 9 Quick-Connect Swivel Fittings - 18 Hanger Bolts - 9 lock nuts 42" Hardware Kit - 9 Quick-Connect Fittings - 9 Quick-Connect Swivel Fittings - 22 Hanger Bolts - 11 lock nuts			

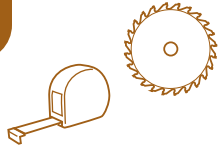
1



INSTALL POST SLEEVES

- Trim Post Sleeves to desired length.
- Slide Post Sleeves and Post Skirt over post (do not force). Post sleeve will be slightly larger than the post.
- Ensure posts are square and plumb. Shim as needed to plumb.

! IMPORTANT NOTES:

Be sure to cut Post Sleeves such that finished rail height is at least 36" high for a 36" rail application and 42" high for a 42" application.

For all rail installations, post and post covers must be plumb and aligned with one another.

For Over-the-Post applications, it is critical that Posts be of a consistent height (e.g. the tops of all post sleeves are level and on plane with each other).

TIP: To ensure that the tops of all post sleeves are level, you may use a traditional 8 ft. level or a string line to establish a common level across all post sleeves and cut at that level. Alternatively, you may use a laser level to "shoot" a level mark on each post sleeve and then cut at that mark.

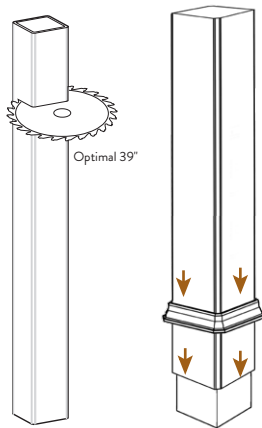

39" above deck surface is optimal for 36" railing heights.

2

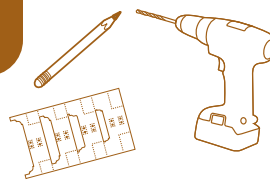

INSTALL LOWER SUPPORT BLOCKS

- Position template at bottom of Post Sleeve above Post Skirt.

If you do not have the template, position the top of the Support Block 4" above the deck.

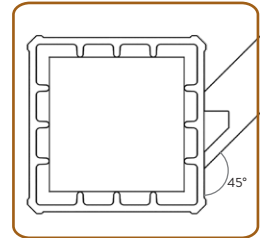

For angled rail installations, align angled face of Support Block parallel to rail section.

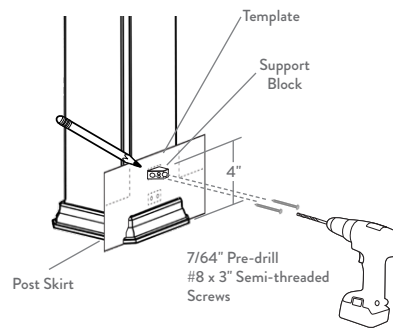

3

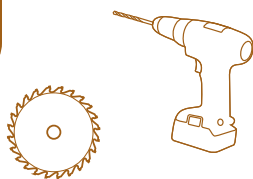

CUT AND ASSEMBLE BOTTOM SUPPORT RAIL

- Cut the Bottom Support Rail to length.
- Add support blocks as required.
- Attach brackets.

! For sections up to 6': Place one Foot Block in the center of the rail.

For sections 6' to 8': Space two Foot Blocks approximately at 1/3 intervals on the rail.

For sections 8' to 10': Space three Foot Blocks approximately at 1/4 intervals on the rail.

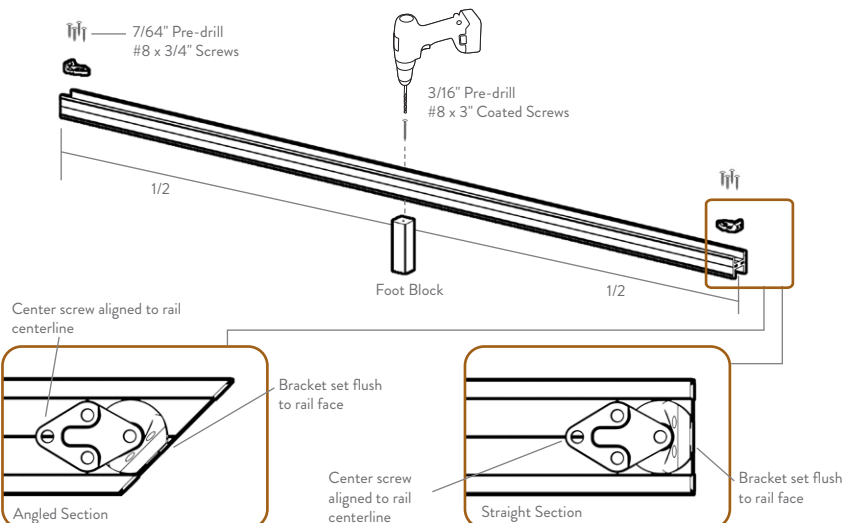

4



INSTALL BOTTOM SUPPORT RAIL

- Position Bottom Support Rail assembly onto Support Blocks.
- Pre-drill holes into post sleeves only.
- Attach brackets with green coated screws.

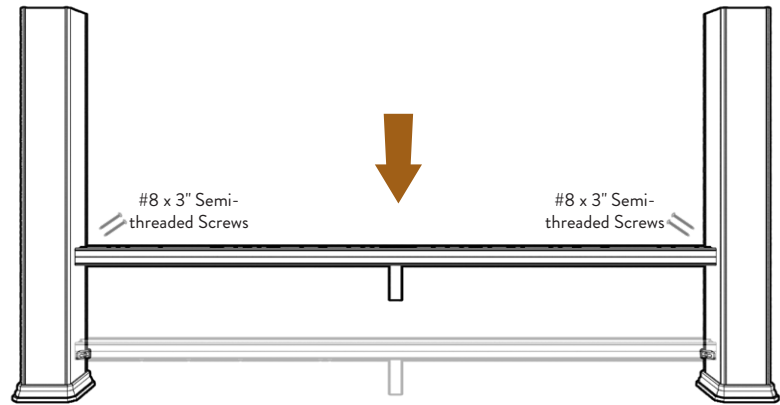
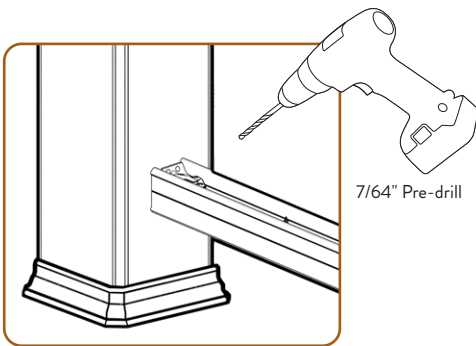

5

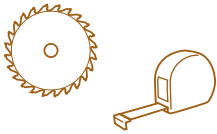

CUT AND PREP UNIVERSAL BOTTOM RAIL AND TOP SUPPORT RAIL

- Measure distance between the posts at the Universal Bottom Rail and Top Support Rail.
- Cut Universal Bottom Rail and Top Support Rail to length.
- Attach Brackets to the Top Support Rail.
- Use Intermediate Base Plate as a template for predrilling hole for intermediate baluster.



6' sections require 1 Intermediate Baluster;
8' sections require 2 Intermediate Balusters;
10' sections require 3 Intermediate Balusters.

For 10' rail sections utilizing aluminum support rail, when attaching Mounting Brackets at each end of the Top Support Rail, pre-drill using a 9/64" drill bit (instead of 7/64" bit).

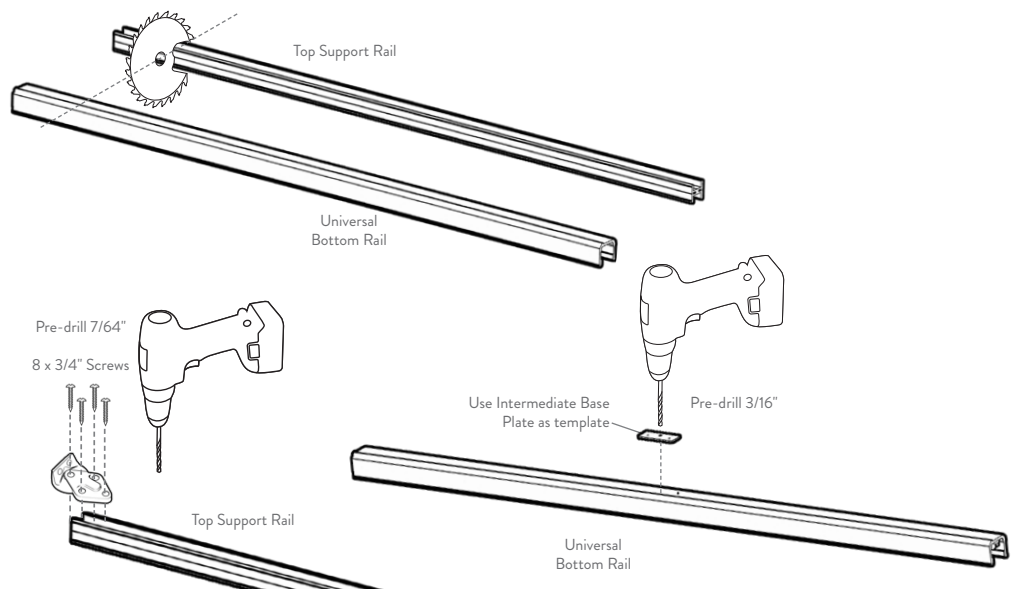

6



ATTACH INTERMEDIATE BALUSTERS

- Attach Intermediate Baluster to Universal Bottom Rail Profile.

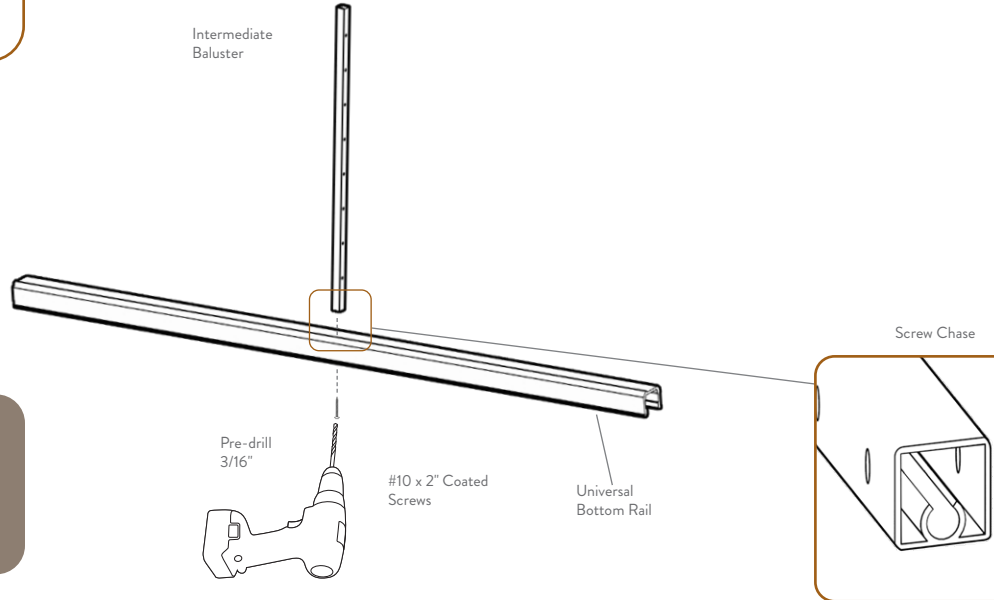

7

INSTALL UNIVERSAL BOTTOM RAIL

- Place the Universal Bottom Rail between the posts and allow the rail to rest on the Bottom Support Rail.

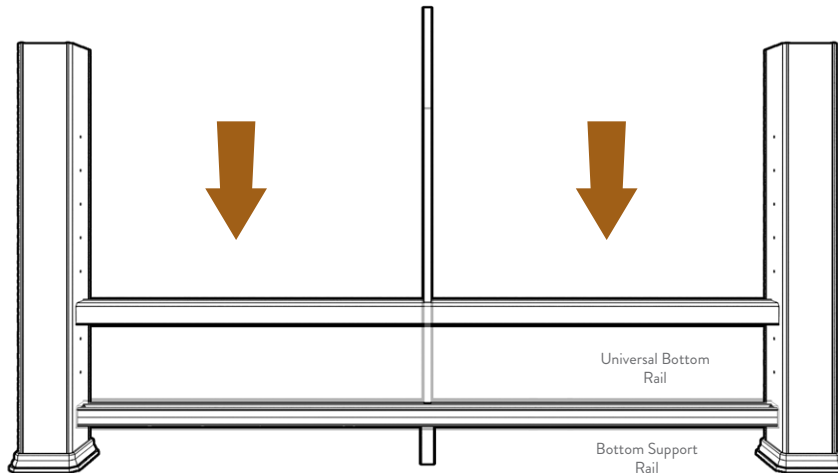

8

TRANSFER HOLE LOCATION ONTO POST SLEEVE

- Use an extra Intermediate Baluster, rested on the Universal Bottom Rail, as a template for the CableRail Hardware and through holes.
- Using a 3/16" drill bit to transfer your marks onto the Post Sleeve.

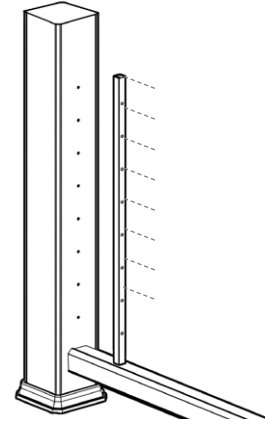

9

ATTACH TOP SUPPORT RAIL

- Attach Intermediate Baluster Base Plate to Top Support Rail

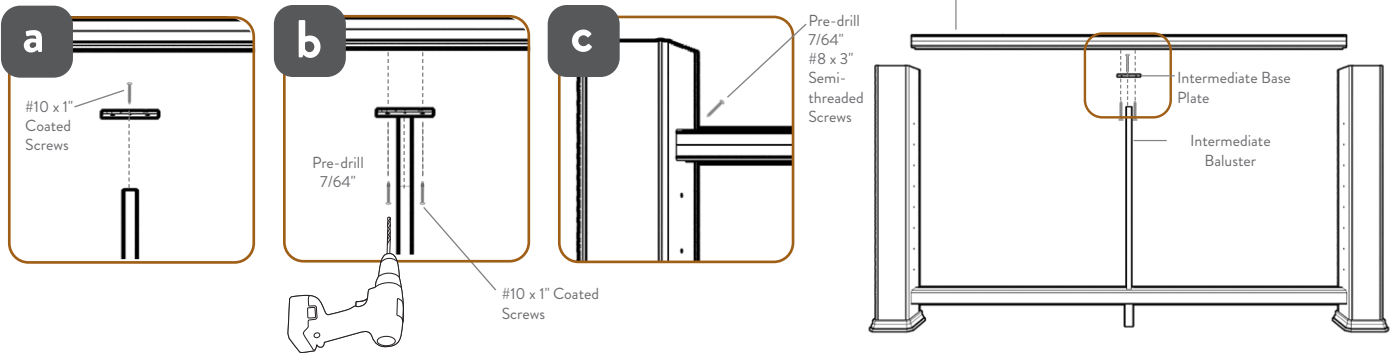

NOTE: If installing a Deck Board as a Top Rail, please refer to Drink Rail Install Guide.

10

INSTALL TOP RAIL AND POST CAPS

- Measure and cut Top Rail (not included) to length. Trim both ends for a clean cut. If installing Deck board as Drink Rail, please refer to Drink Rail Install Guide
- Attach Top Rail using 1 5/8" screws, driving screws up through bottom of support rail into Top Rail.
- Attach Post caps using exterior grade caulk applied to the underside of the cap.

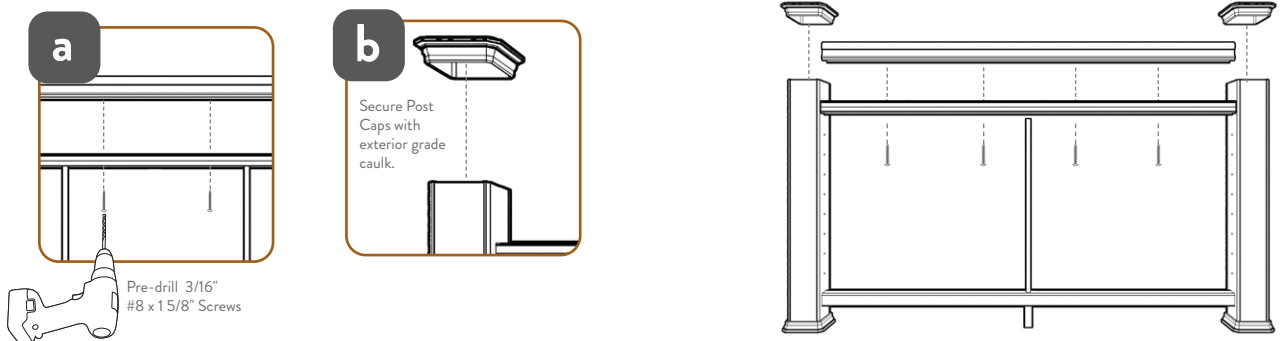

11

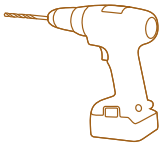

PRE-DRILL ANCHOR POST SLEEVE

- Using the marks on the Anchor Posts, drill a through hole only in the Post Sleeve with a 1/4" Bit drill.

Warning: Anchor posts should not exceed 60 feet apart during any continuous run of cable.

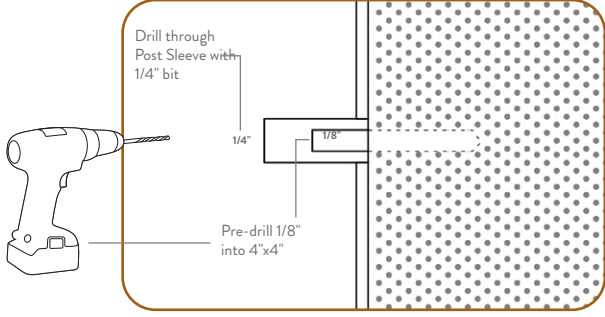

12

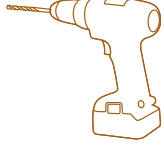

PRE-DRILL THROUGH POST SLEEVES

- For the through posts, drill a 1/4" hole through both the Post and Post Sleeve.

Optional - Protector Sleeves are not required on the through posts, but do offer a more finished appearance.

Use a dab of adhesive on Protector Sleeve if needed.

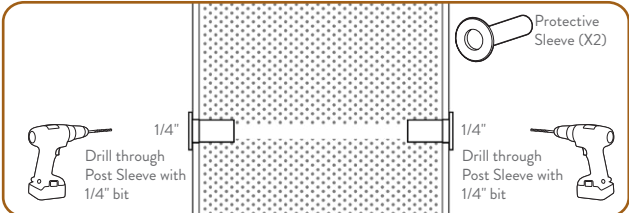

13

DRIVE IN HANGER BOLTS

- On Anchor Posts, screw the Hanger Bolts into the pilot holes in the Post with the Hanger Bolt Installation Tool (included with CableRail Accessory Kit, purchased separately).
- Once Hanger Bolts are all driven in, then screw on Quick-Connect Fittings.

Leave about 1" of machine thread exposed for cable take-up.

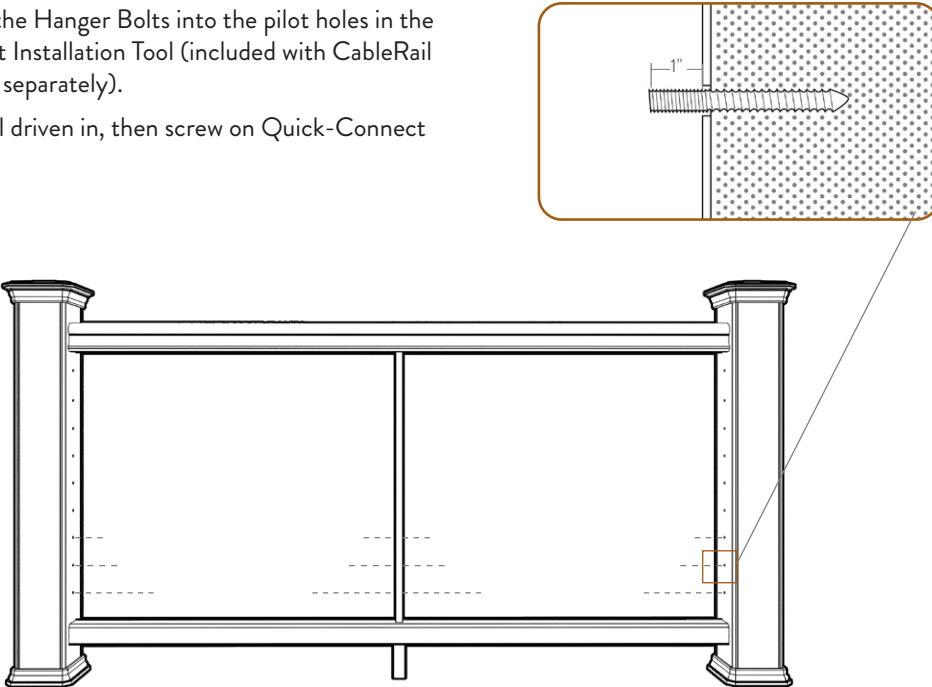

14

ATTACH QUICK-CONNECT AND QUICK-CONNECT SWIVEL FITTINGS

- Screw on Quick-Connect fittings snugly against Post Sleeve onto one side of the railing and lock nuts onto hanger bolts on the other side.
- Screw on Quick-Connect Swivel fitting onto the Hanger Bolt with the lock nut already installed.

One side of the railing will be only Quick-Connect fittings, the other side will be Quick Connect swivel fittings and lock nuts.

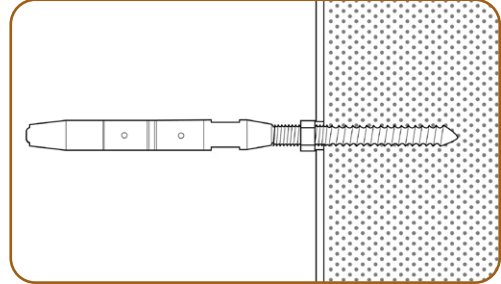
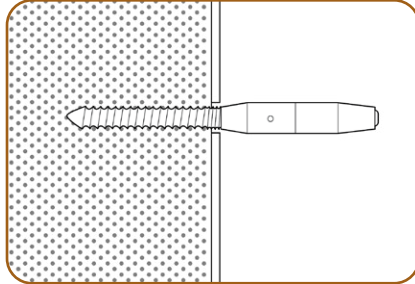

15



INSERT AND THREAD CABLE

- When all of the hardware is in place, insert one end of the Cable into the Quick-Connect fitting.
- Feed the Cable through the Intermediate Baluster (or through posts) with a lacing needle.

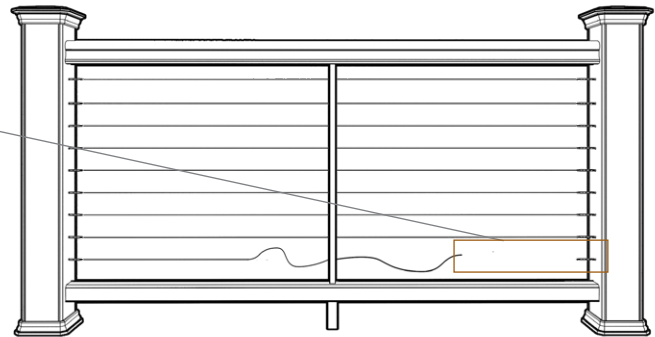
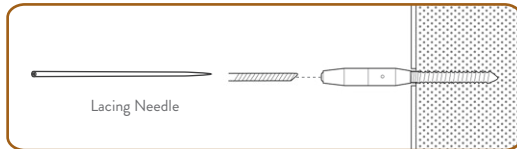

16

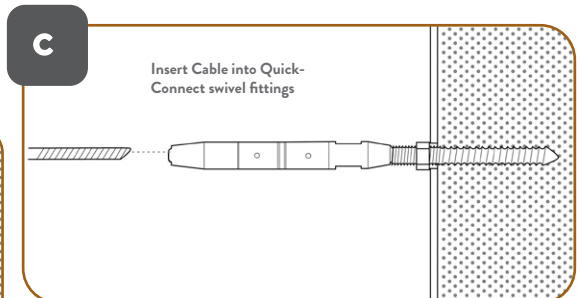
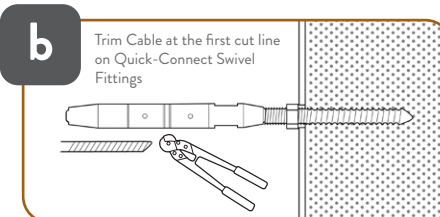
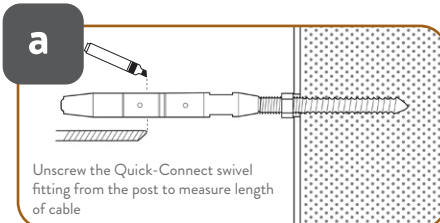
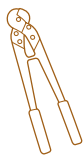

17

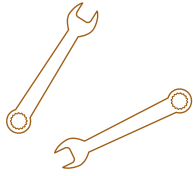

ATTACH QUICK-CONNECT AND QUICK-CONNECT CABLE FITTINGS

- Use a set of 3/8" open-ended wrenches to tighten the Cables using the "swivel" end, insuring the Cables do not twist. Tighten the center cable first, then in an alternating pattern from top to bottom.
- Once the Cable is tight, tighten the lock nuts against the Quick-Connect swivel fitting.

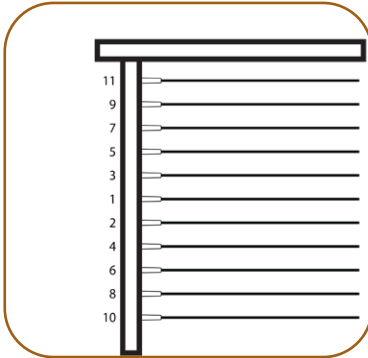

Tightening Order

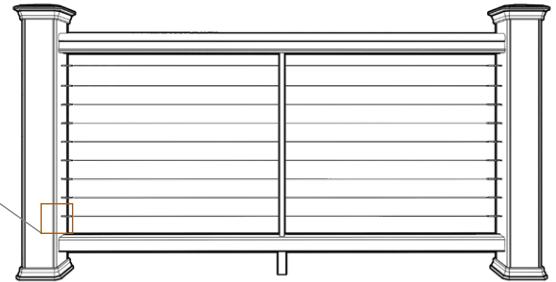
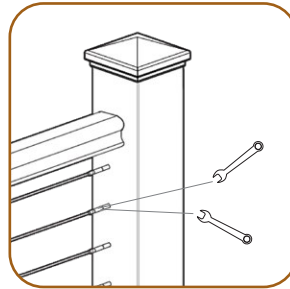

If necessary, the Cable can be removed from the Quick-Connect fitting by using the Quick-Connect Release Tool.

1

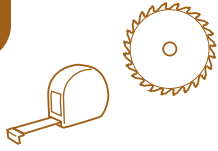

INSTALL POST SLEEVES

- Trim Post Sleeves to desired length.
- Slide Post Sleeves and Post Skirt over post (do not force). Post sleeve will be slightly larger than the post.
- Ensure posts are square and plumb. Shim to plum as needed.

IMPORTANT NOTES:

Be sure to cut Post Sleeves such that finished rail height is at least 36" high for a 36" rail application and 42" high for a 42" application.

For all rail installations, post and post covers must be plumb and aligned with one another.

For Over-the-Post applications, it is critical that Posts be of a consistent height (e.g. the tops of all post sleeves are level and on plane with each other).

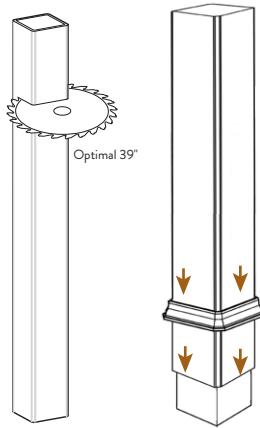

2

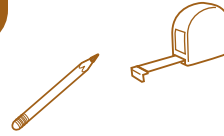

MEASURE SUPPORT RAILS

- Determine measurements and angle as shown.
- Trim both the Top Support Rail and the Bottom Support Rail to those dimensions.
- Test fit rails to check for accuracy.

Support Rails are rotated 90° for stair rail applications.

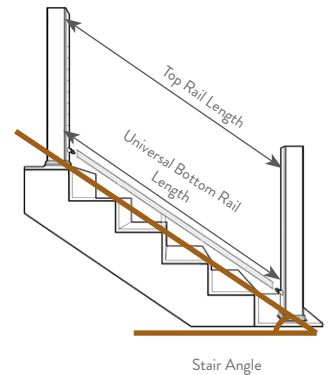
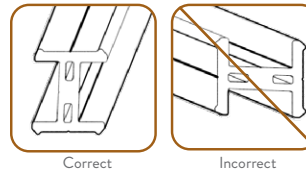

3

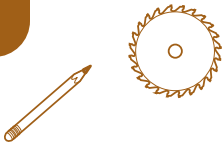

TRIM RAILS

- Transfer measurement from both Support Rails to Universal Bottom Rail and Top Rail.
- Trim Top Rail and Universal Bottom Rail to match the Support Rails at the appropriate angle.

! This entire section of instructions is for installation of Classic Composite Series and Reserve Rail systems. Installation of the RESERVE RAIL system is identical to the Classic Composite Series, except it uses the RESERVE BOTTOM RAIL instead of the Universal Bottom Rail.

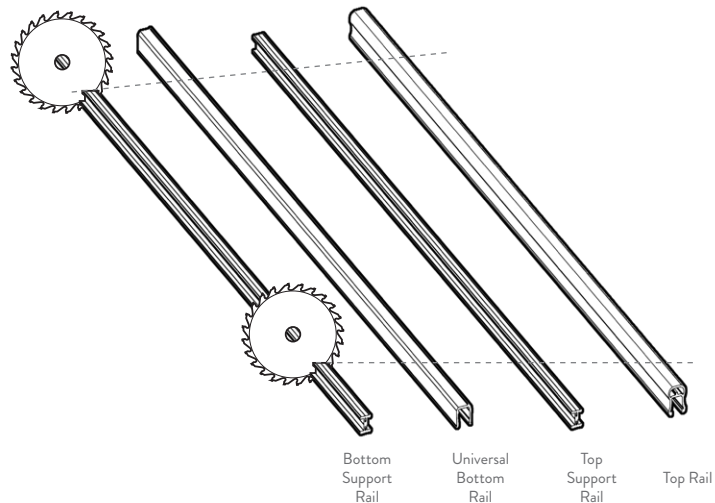

4

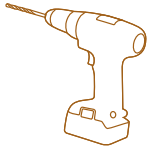

PREP BOTTOM SUPPORT RAIL

- Attach Mounting Brackets to Bottom Support Rail.

- Trim and Attach Foot Blocks.

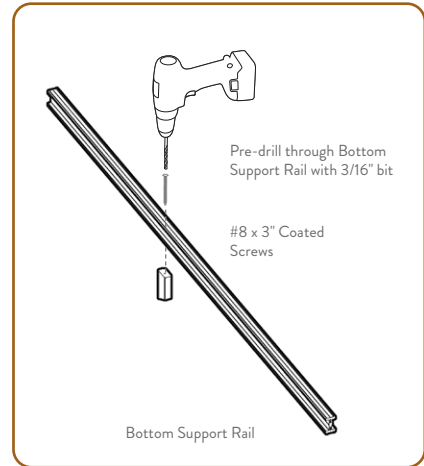
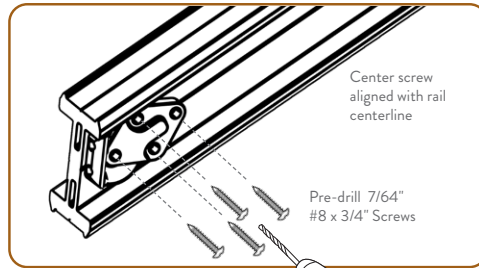

For sections up to 6': Place one Foot Block in the center of the rail.

For sections 6' to 8': Space two Foot Blocks approximately at 1/3 intervals on the rail.

5

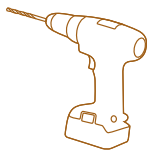

INSTALL BOTTOM SUPPORT RAIL

- Secure Mounting Brackets.



Brackets must be installed to the stair tread side of the rail.

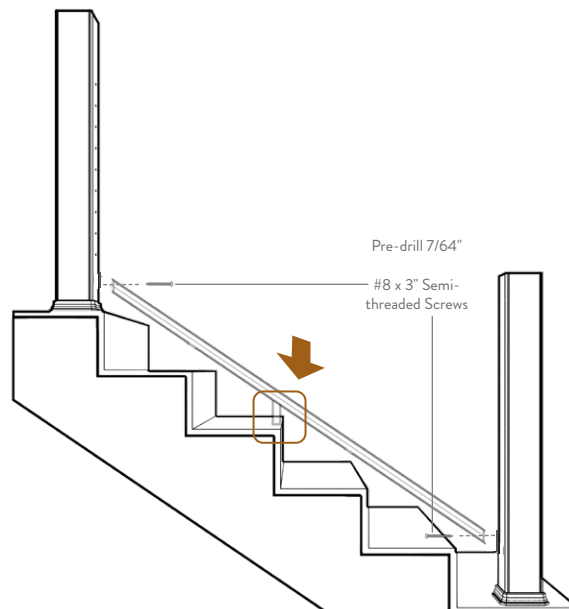

6



PRE-DRILL UNIVERSAL BOTTOM RAIL

- Use Intermediate Base Plate as a template for predrilling hole for intermediate baluster.

Use the Intermediate Base Plate as a Template, as shown to the right.

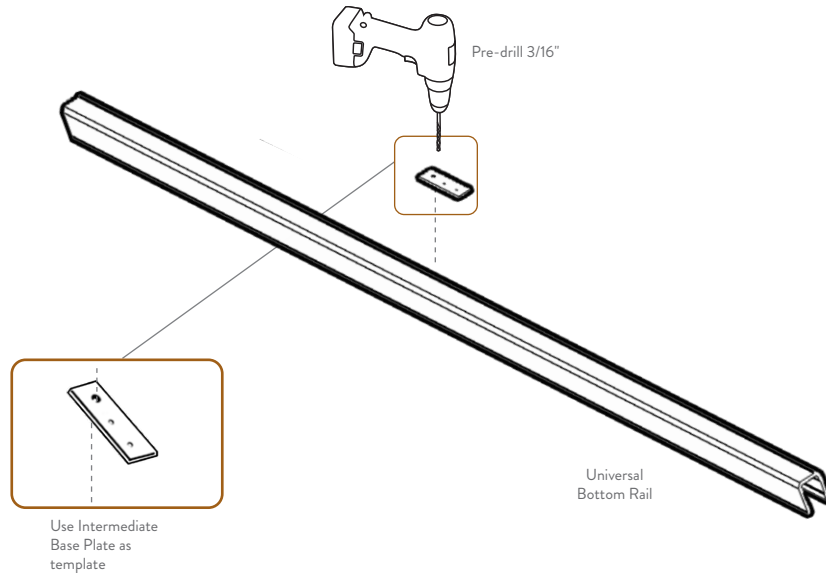

7



ATTACH STAIR INTERMEDIATE BALUSTER

- Trim Stair Intermediate Baluster to match stair angle.



Be sure the screw finds the screw chase

For easier installation, pre-drill screw chase with a 3/16" drill bit.

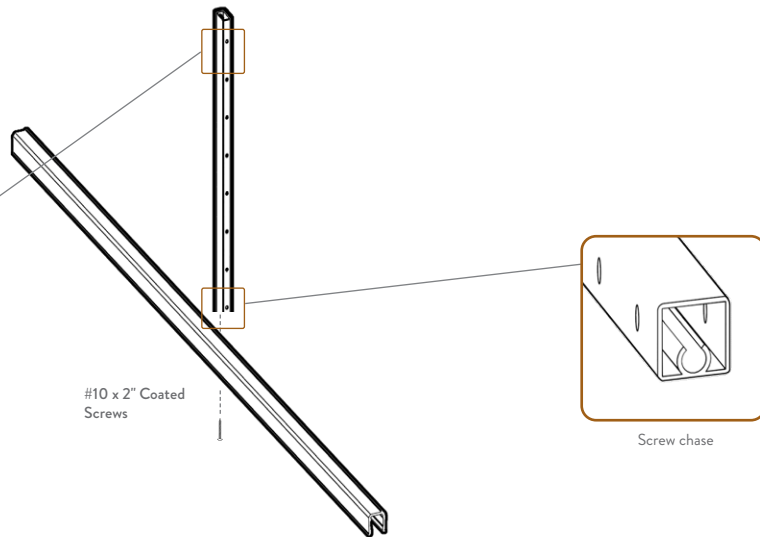
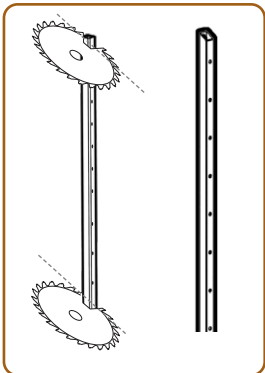

8

INSTALL UNIVERSAL BOTTOM RAIL

Lower the rails perpendicular to the deck surface.

- Place the Universal Bottom Rail over the Bottom Support Rail with the Intermediate Baluster(s).

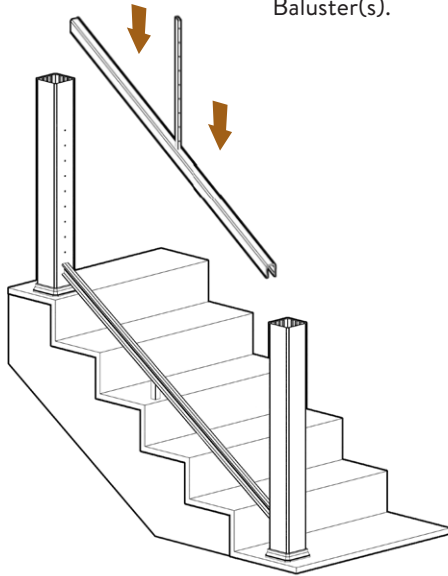

9

TRANSFER HOLE LOCATION ON POST SLEEVE



- Use an extra Intermediate Baluster as a template to mark for CableRail hardware and through holes.

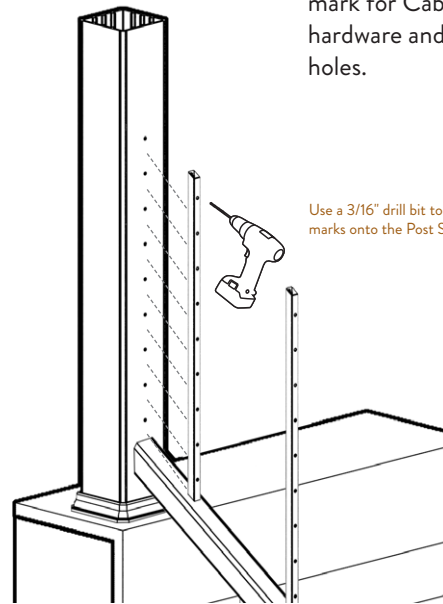

Use a 3/16" drill bit to transfer marks onto the Post Sleeve

10

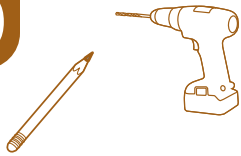

ATTACH TOP SUPPORT RAIL

- Mark ends of top support rail for position of support block.
- Rotate Rail assembly out of way to fasten Support Block.
- Secure Mounting Brackets to Posts.

a

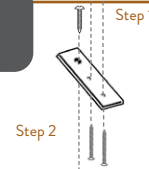

Step 1

Step 2

b

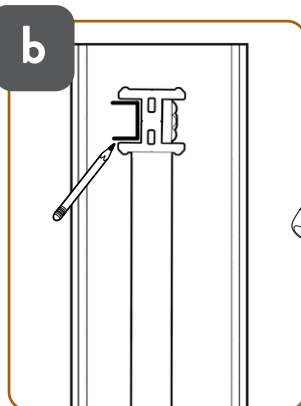

c

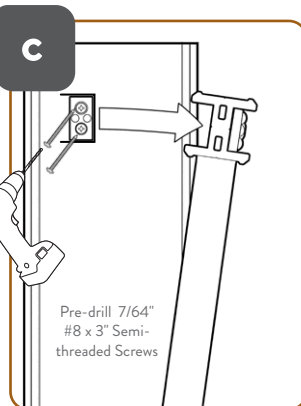

Pre-drill 7/64" #8 x 3" Semi-threaded Screws

d

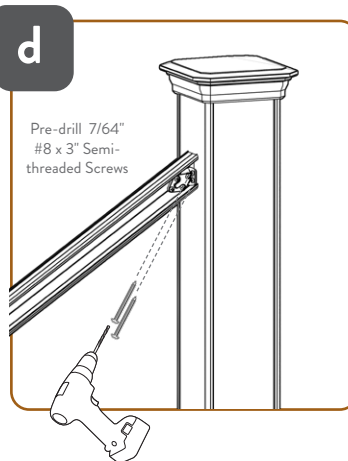

Pre-drill 7/64" #8 x 3" Semi-threaded Screws

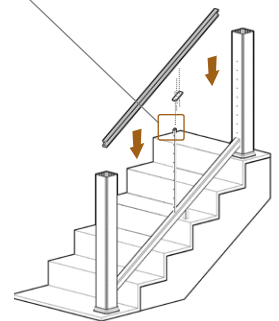

NOTE: If installing a Deck Board as a Top Rail, please refer to Drink Rail Install Guide.

11



INSTALL TOP RAIL AND POST CAPS

- Position Top Rail over Support Rail and attach with screws.
- Attach Top Rail using 2 5/8" screws, driving screws up through bottom of support rail into Top Rail.
- Secure Post Caps with exterior grade caulk.

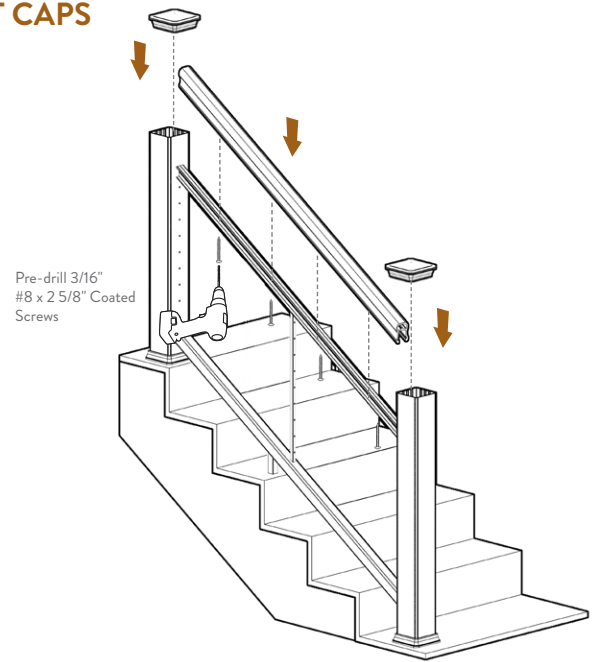

12



PRE-DRILL ANCHOR POST SLEEVE

Drill a through hole only in the post sleeve with a 1/4" drill bit at the same angle as the stair run



Use a scrap piece of baluster trimmed at the stair angle as a guide.

Anchor posts should not exceed 60 feet apart during any continuous run of cable.

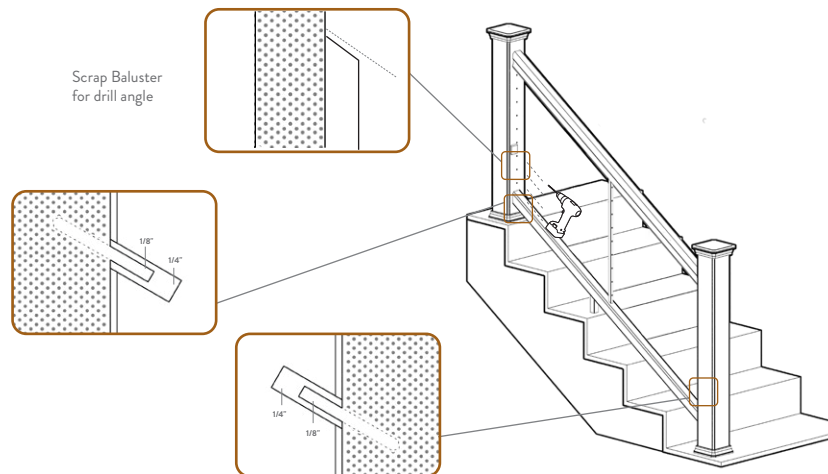

13

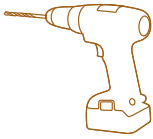

PRE-DRILL THROUGH POST SLEEVES

- Drill a 1/4" hole through both the Post and Post Sleeve at stair angle.

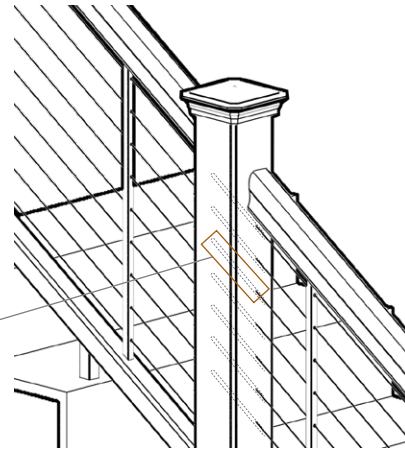
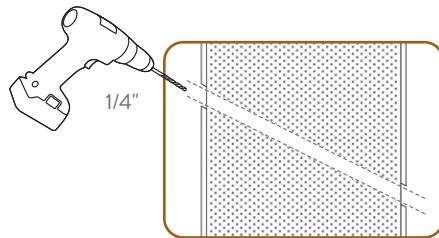

14

DRIVE IN HANGER BOLTS

- On Anchor Posts, screw the Hanger Bolts into the pilot holes in the Post with the Hanger Bolt Installation Tool (included with CableRail Accessory Kit, purchased separately).

Leave about 1" of machine thread exposed for cable take-up.

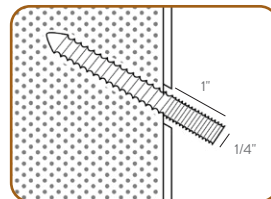

Top Anchor Post

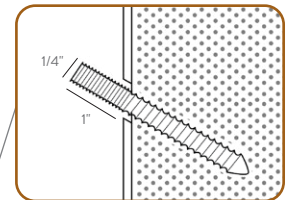
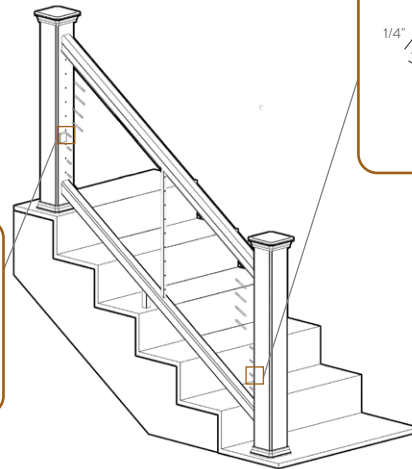

Bottom Anchor Post

15

ATTACH QUICK CONNECT FITTINGS

- Place one Quick-Connect fitting at one end and the Quick-Connect Swivel fitting on the opposite end.



One side of the railing will be only Quick-Connect fittings, the other side will be Quick-Connect swivel fittings and lock nuts.

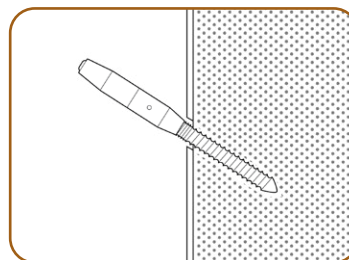

On the side with the lock nuts, screw on the Quick-Connect fittings after the lock nuts, onto the hanger bolts

Quick-Connect fitting with Lock Nut

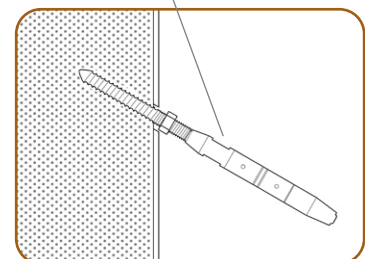

16



THREAD CABLE

- When all of the hardware is in place, insert one end of the Cable into the Quick-Connect fitting.
- Feed the Cable through the Intermediate Baluster (or through posts) with a lacing needle.

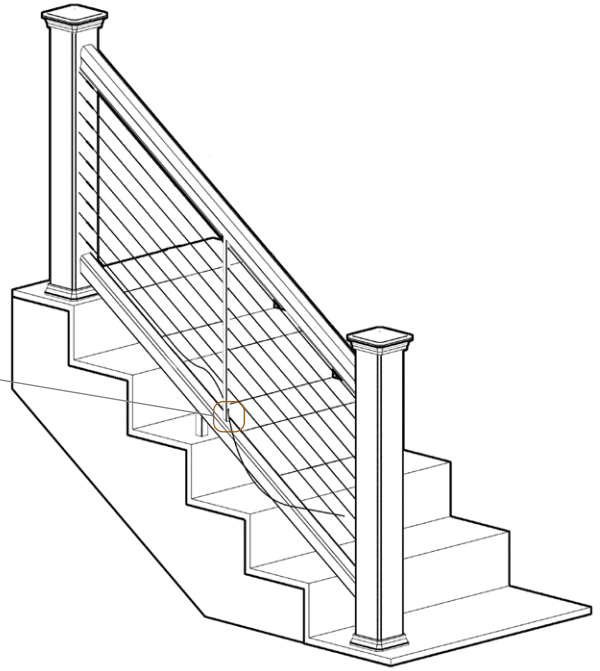
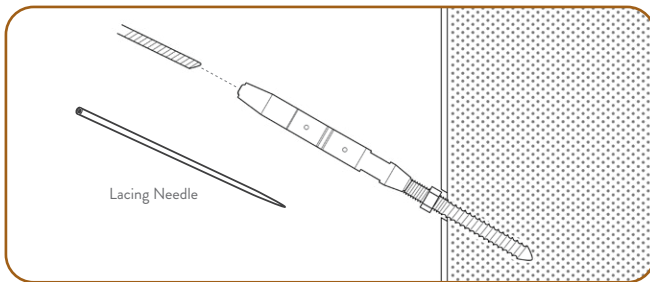

17

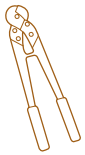

CUT CABLE TO LENGTH

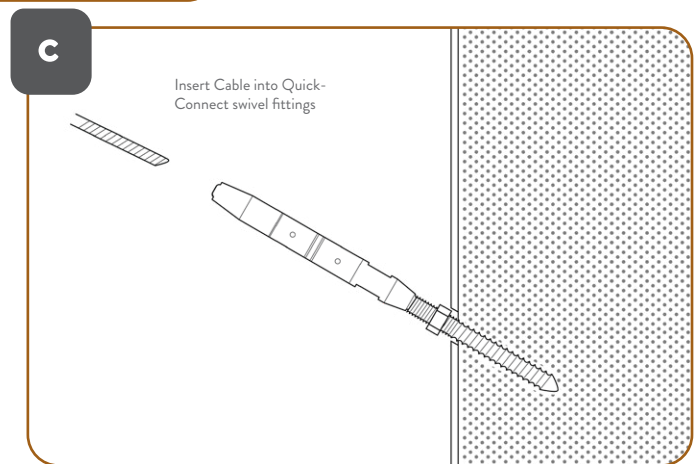
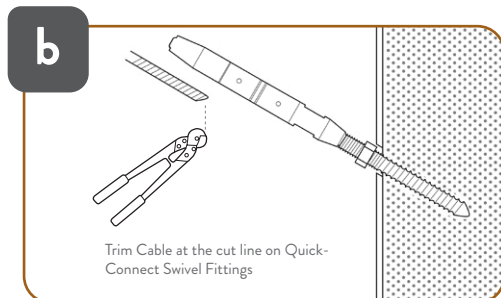
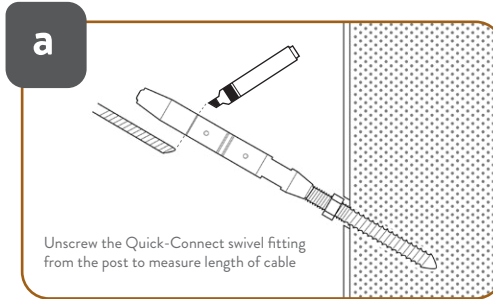

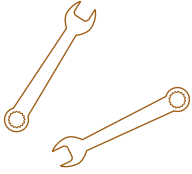

18

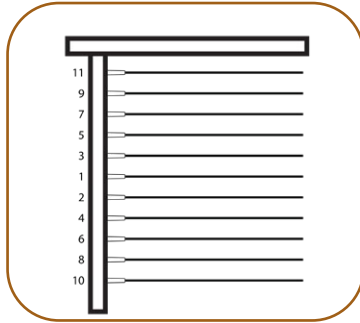

TIGHTEN CABLE

- Use a set of 3/8" open-ended wrenches to tighten the Cables using the "swivel" end, insuring the Cables do not twist. Tighten the center cable first, then in an alternating pattern from top to bottom.
- Once the Cable is tight, tighten the lock nuts against the Quick-Connect swivel fitting.



 If necessary, the Cable can be removed from the Quick-Connect fitting by using the Quick-Connect Release Tool.

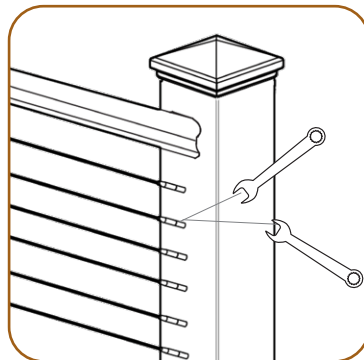

Use a set of 3/8" open-ended wrenches to tighten the Cable using the "swivel" end, insuring the Cable does not twist.

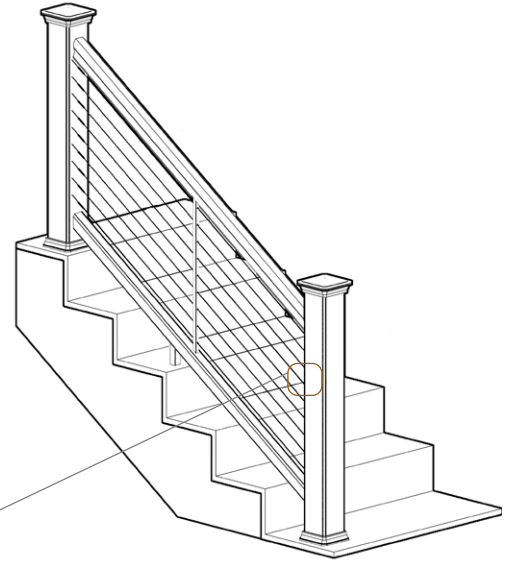

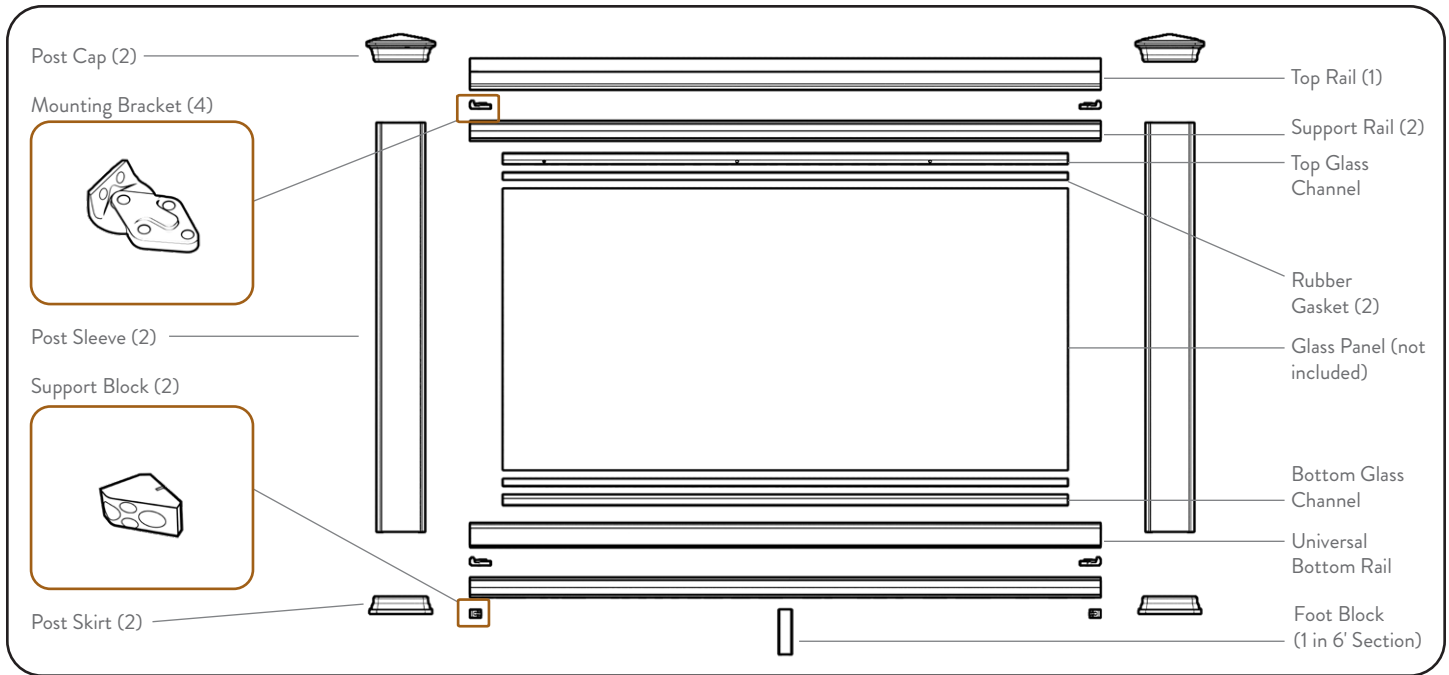

! IMPORTANT NOTES:

- TimberTech Railing for Glass Infill is available in 6' lengths.
- Visit <https://www.timbertech.com/installation-help> to view TimberTech installation videos.
- Consult your local building codes for guard and handrail requirements.
- TimberTech Railing 6' Rails are designed not to exceed 6' from center of post to center of post.
- For all other applications, consult a design professional or a TimberTech Railing representative for more information.
- 4x4 lumber posts must be installed plumb and level with each other.
- Cut slowly, using a thin kerf, finish saw blade to avoid chipping.
- Read instructions completely to get an understanding of how the product goes together and how each piece affects the other.
- For all applications, a structural post must be used inside our Post Sleeve.



This entire section of instructions is for installation of Classic Composite Series and Reserve Rail systems. Installation of the RESERVE RAIL system is identical to the Classic Composite Series, except it uses the RESERVE BOTTOM RAIL instead of the Universal Bottom Rail.

TOOLS REQUIRED

- Miter Saw
- 7/64" Drill Bit
- Measuring Tape
- Drill
- 3/16" Drill Bit
- Caulk Gun

INSTALLING RAILING WITH GLASS INFILL

FOR CLASSIC COMPOSITE SERIES AND RESERVE RAIL



MEASURING YOUR RAILING AREA

- Measurements are from center to center of the posts. Railing components are produced in 6' lengths to allow for finished end cuts and angles.
- Determine how many 6' TimberTech Rail Sections you need and check to be sure you have all the components (and quantities) listed in the chart shown.

COMPONENT DIMENSIONS

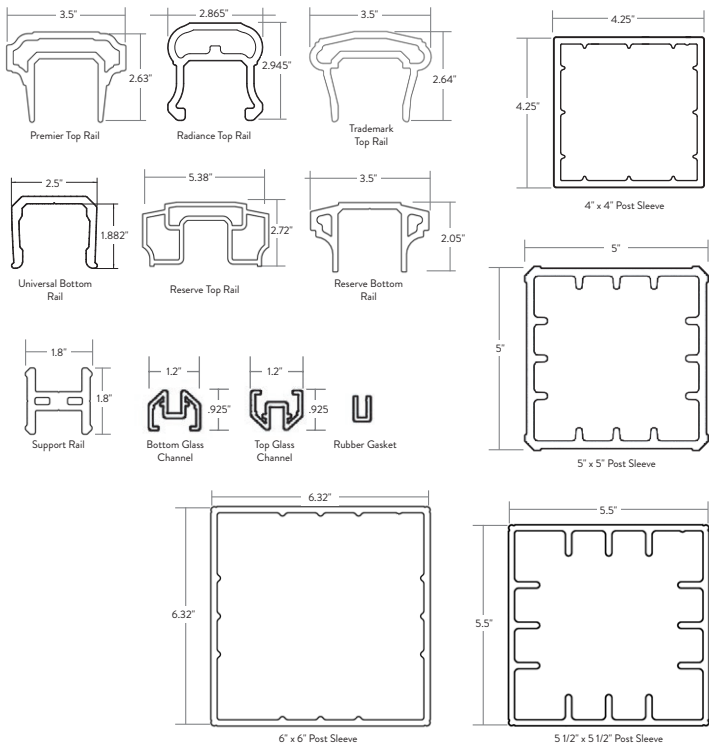

COMPONENTS NEEDED FOR INSTALLING ONE TIMBERTECH RAIL SECTION	
Components available separately for mix-and-match rail systems	TimberTech Custom Rail Pack 1 - Top Rail 1 - Universal Bottom Rail (with Classic Composite Series) 2 - Support Rails Hardware Mounting Kit Support Block Mounting Templates 1 - Foot Block
Hardware included in Hardware Kits:	4 - Mounting Brackets 2 - Support Blocks 16 - #8 x 3/4" Screws 6 - #8 x 1 5/8" Screws 6 - #8 x 2 5/8" Screws (Stairs Only) 6 - #8 x 3" Screws 12 - #8 x 3" Semi-threaded Screws T20 Driver Bit
Glass Hardware Pack	1 - Top Glass Channel 1 - Bottom Glass Channel 2 - Rubber Gaskets 6 - #8 x 2 1/4" Screws 6 - #8 x 3" Screws 3 - #8 x 1" Screws
Additional Components Needed for Each System	 1/4" Tempered Glass must be sourced locally (See attached reference sheet). 2 - Post Caps 2 - Post Sleeves 2 - Post Skirts

DIMENSIONAL CONSTRAINTS FOR STRAIGHT SECTION

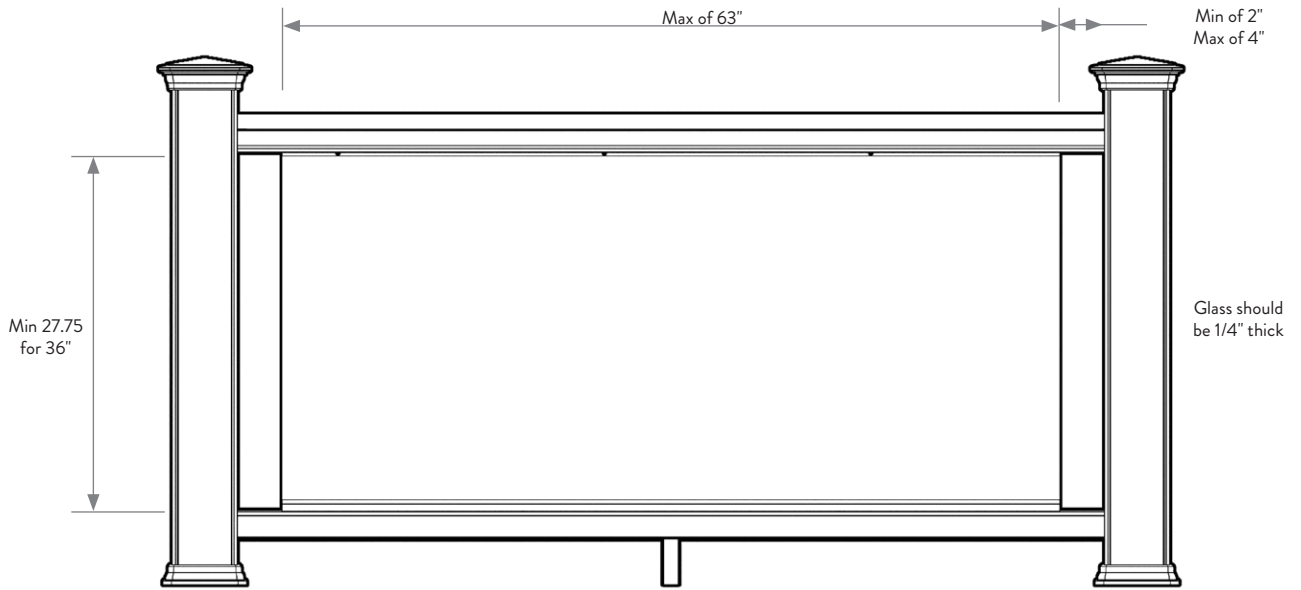

DIMENSIONAL CONSTRAINTS FOR STAIR SECTION

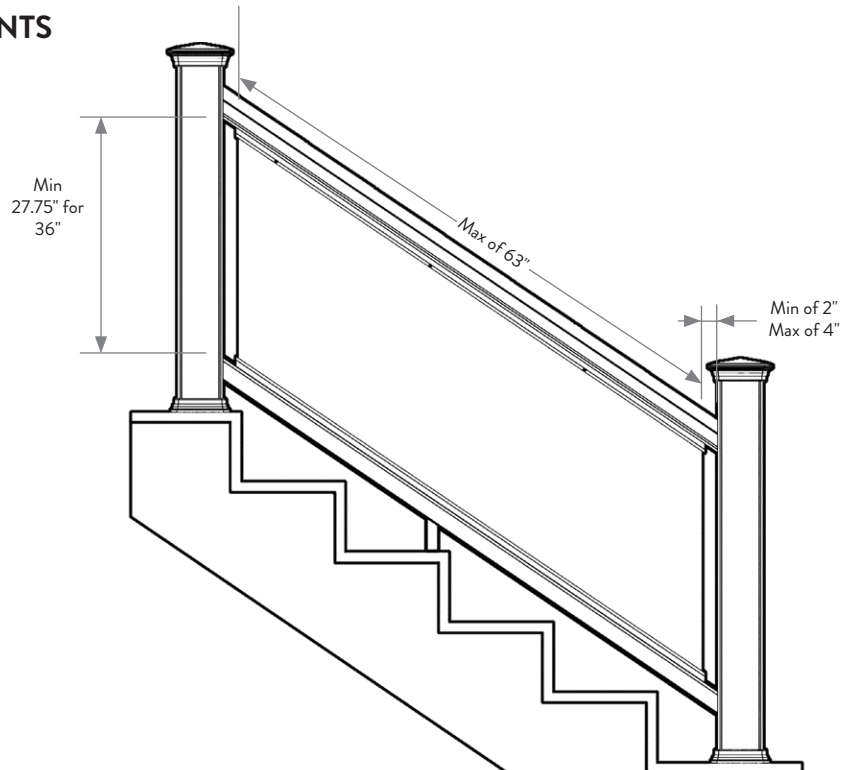

INSTALLING RAILING WITH GLASS INFILL

FOR CLASSIC COMPOSITE SERIES AND RESERVE RAIL



1

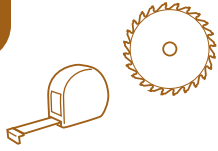

INSTALL POST SLEEVES

- Trim Post Sleeves to desired length.
- Slide Post Sleeves and Post Skirt over post (do not force). Post sleeve will be slightly larger than the post.
- Ensure posts are square and plumb. Shim as needed to plumb.

IMPORTANT NOTES:

Be sure to cut Post Sleeves such that finished rail height is at least 36" high for a 36" rail application and 42" high for a 42" application.

For all rail installations, post and post covers must be plumb and aligned with one another.

For Over-the-Post applications, it is critical that Posts be of a consistent height (e.g. the tops of all post sleeves are level and on plane with each other).

TIP: To ensure that the tops of all post sleeves are level, you may use a traditional 8 ft. level or a string line to establish a common level across all post sleeves and cut at that level. Alternatively, you may use a laser level to "shoot" a level mark on each post sleeve and then cut at that mark.

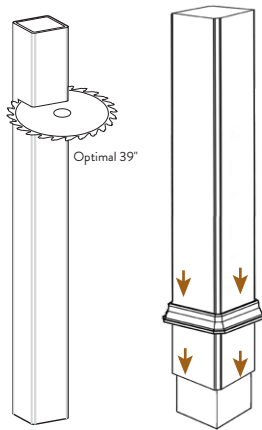

39" above deck surface is optimal for 36" railing heights.

2

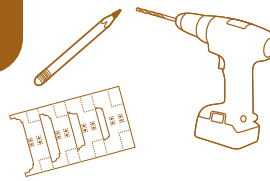

INSTALL LOWER SUPPORT BLOCKS

- Position template at bottom of post sleeve above post skirt.

If you do not have the template, position the top of the Support Block 4" above the deck.

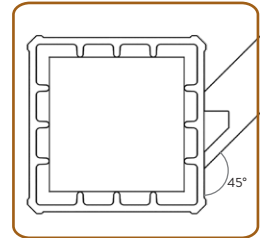

For angled rail installations, align angled face of Support Block parallel to rail section.

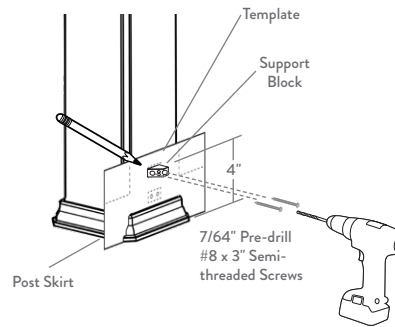

3

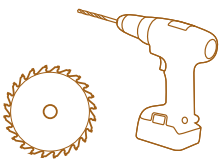

CUT AND ASSEMBLE BOTTOM SUPPORT RAIL

- Cut the Bottom Support Rail to length.
- Add support blocks as required.
- Attach brackets.

For sections up to 6': Place one Foot Block in the center of the rail.

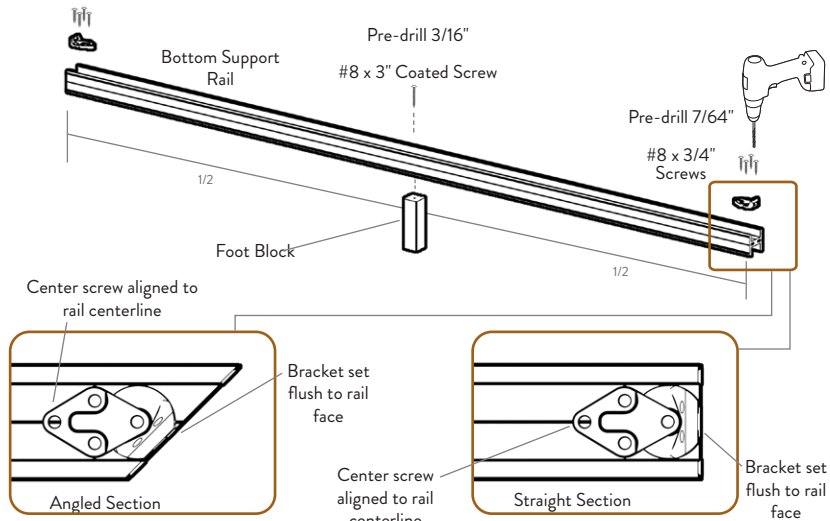

4

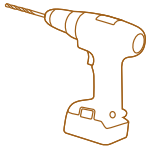

INSTALL BOTTOM SUPPORT RAIL

- Position Bottom Support Rail assembly onto Support Blocks.
- Pre-drill holes into post sleeves only.
- Attach brackets with green coated screws.

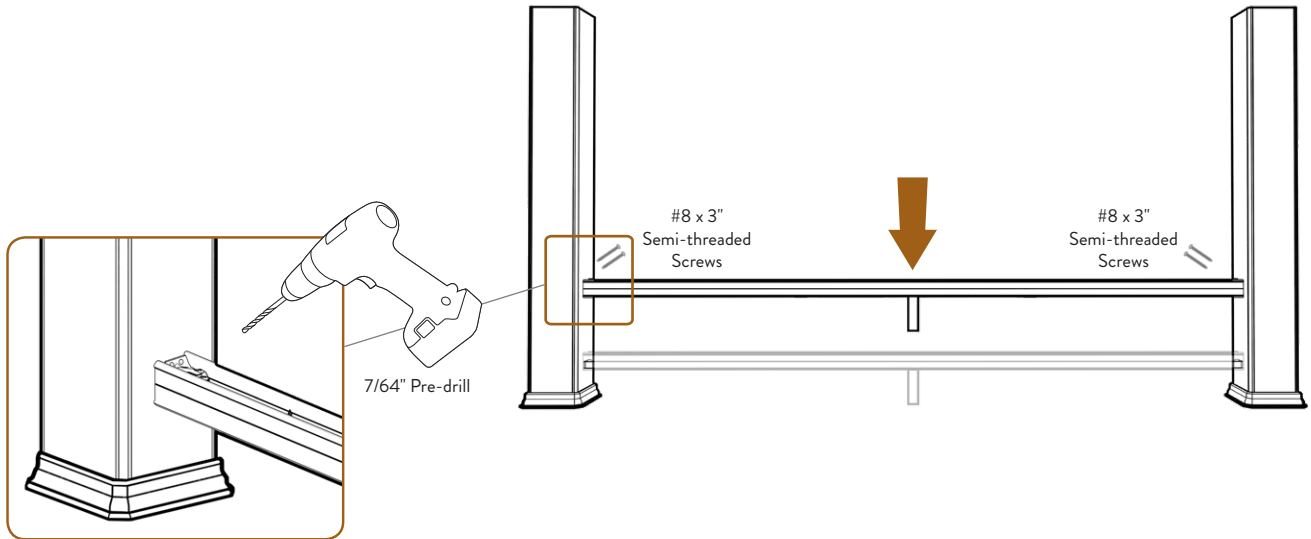

5

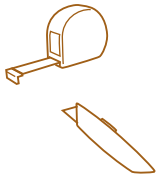

TRIM RAILS, EXTRUSIONS, AND GASKETS

- Measure distance between the posts at the Bottom Support Rail.
- Transfer measurement to Top & Universal Bottom Rails, Top Support Rail and cut to length.
- Measure and cut Top and Bottom Glass Channels, and Rubber Gaskets to appropriate lengths.

! Glass Channels must be at least 4" shorter than rail.

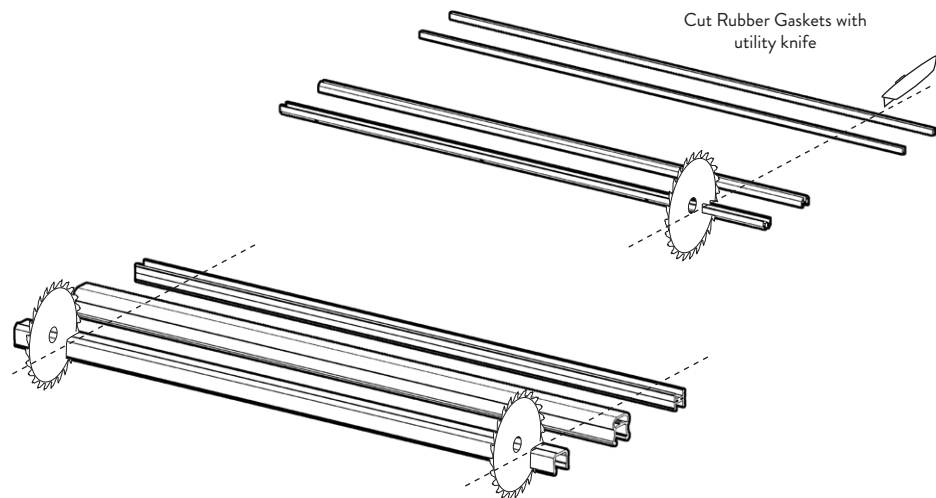

6

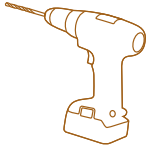

ASSEMBLE LOWER RAIL SECTION

- Place Universal Bottom Rail over Bottom Support Rail.
- Install Bottom Glass Channel utilizing pre-drilled holes.

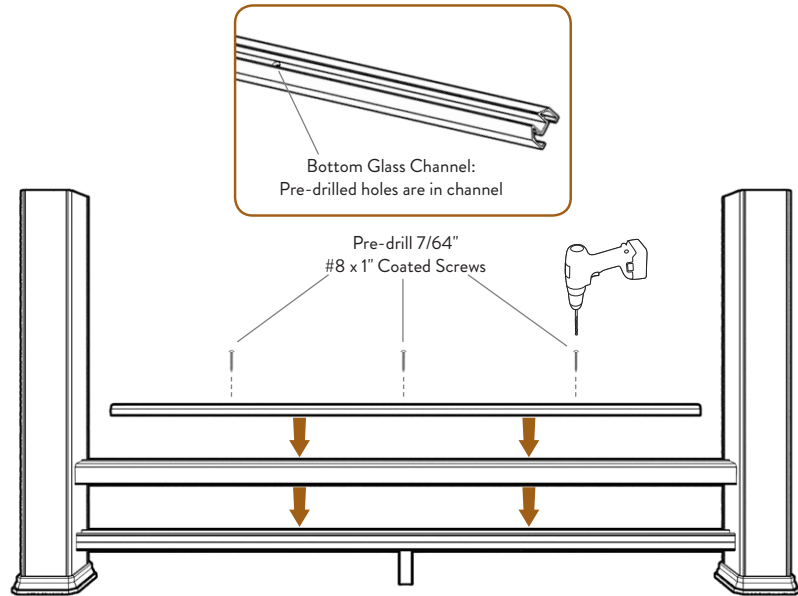

7

ATTACH LOWER GASKET AND INSTALL GLASS PANEL

- Apply Rubber Gasket to bottom of Glass Panel first.
- Set panel/gasket assembly into Bottom Glass Channel.

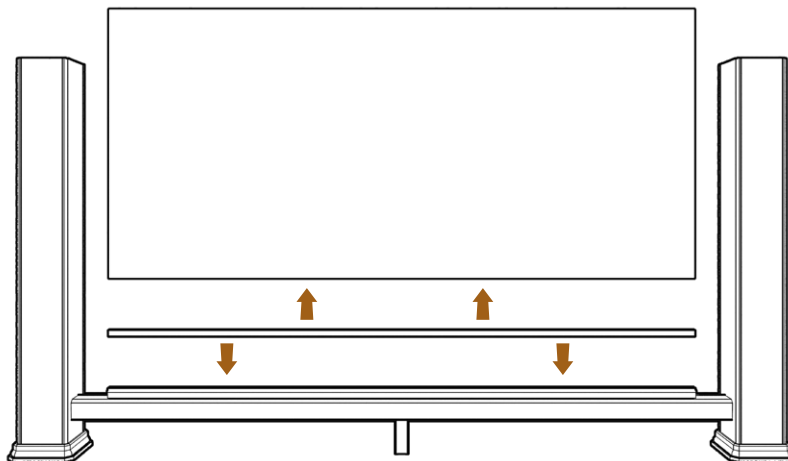

8

INSTALL TOP GASKET AND TOP GLASS CHANNEL

- Place Rubber Gasket on top of glass panel.
- Fit Top Glass Channel onto glass panel assembly.

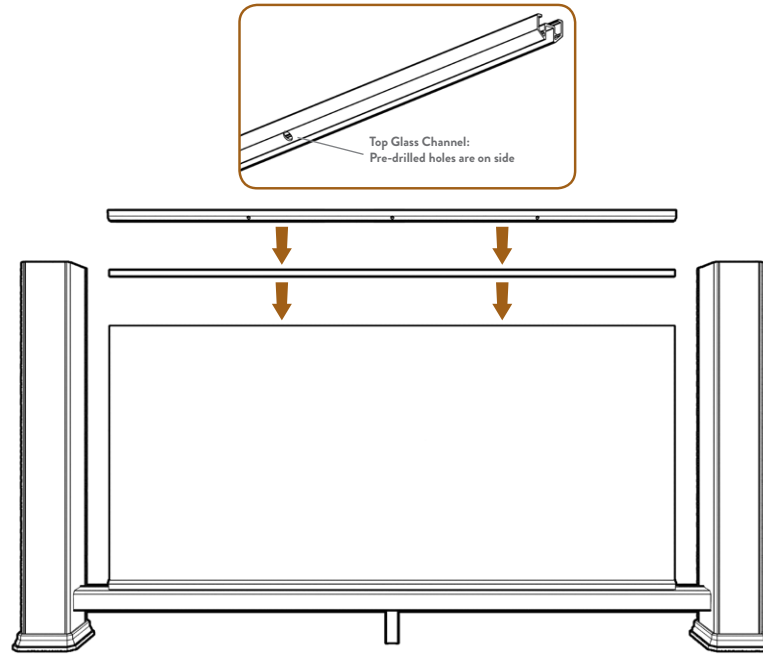

9



INSTALL TOP SUPPORT RAIL

- Align top Support Rail to center of Posts.
- Attach Brackets to Top Support Rail.

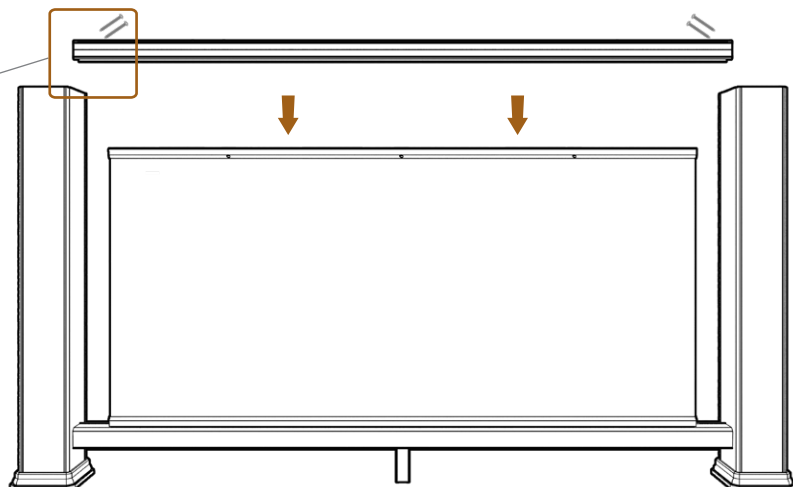
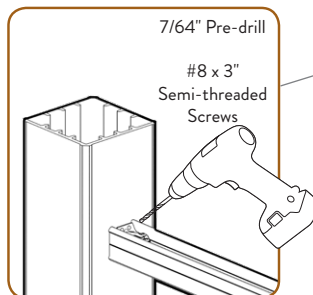
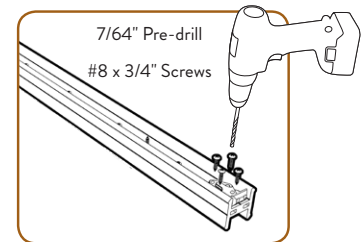

10



INSTALL TOP RAIL AND POST CAPS

- Attach Post Caps using exterior grade caulk applied to the underside of the Cap.
- Attach Top Rail using 2 1/4" coated screws driving screws up through Top Glass Channel into Top Rail.

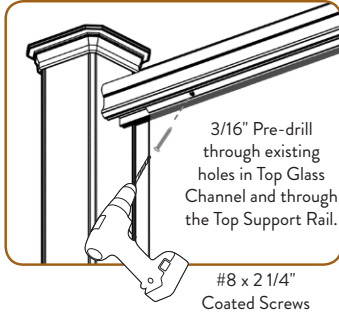

Caution: Screws must be 2 1/4" to attach the Top Rail on the Straight Rail sections.

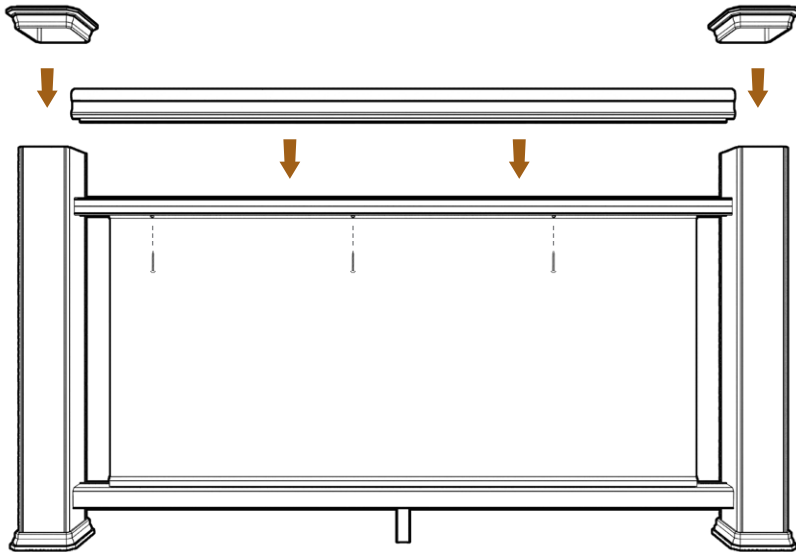



Consult your local building codes for guard and handrail requirements.

1

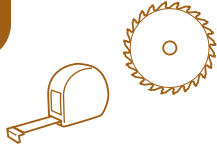

INSTALL POST SLEEVES

- Trim Post Sleeves to desired length.
- Slide Post Sleeves and Post Skirt over post (do not force). Post sleeve will be slightly larger than the post.
- Ensure posts are square and plumb. Shim as needed to plumb.



IMPORTANT NOTES:

Be sure to cut Post Sleeves such that finished rail height is at least 36" high for a 36" rail application and 42" high for a 42" application.

For all rail installations, post and post covers must be plumb and aligned with one another.

For Over-the-Post applications, it is critical that Posts be of a consistent height (e.g. the tops of all post sleeves are level and on plane with each other).

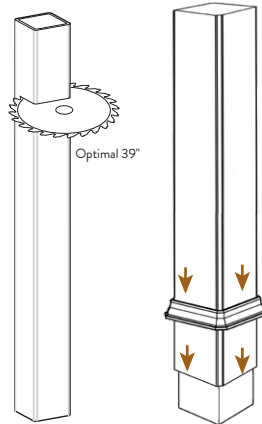

2

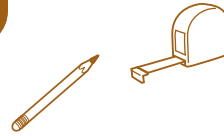

MEASURE SUPPORT RAILS

- Determine measurements and angle as shown.
- Trim both the Top Support Rail and the Bottom Support Rail to those dimensions.
- Test fit rails to check for accuracy.

Support Rails are rotated 90° for stair rail applications.

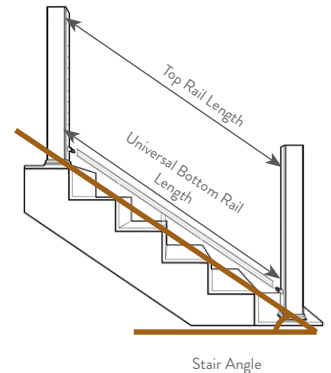
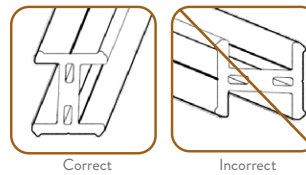

3

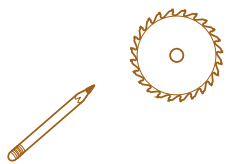

TRIM RAILS

- First trim both Top and Bottom Support Rails to dimensions from Step 2. TEST FIT for accuracy.
- Transfer measurement from Bottom and Top Support Rails to Bottom and Top Rails.
- Trim all Rails to measured lengths at appropriate angle.



This entire section of instructions is for installation of Classic Composite Series and Reserve Rail systems. Installation of the RESERVE RAIL system is identical to the Classic Composite Series, except it uses the RESERVE BOTTOM RAIL instead of the Universal Bottom Rail.

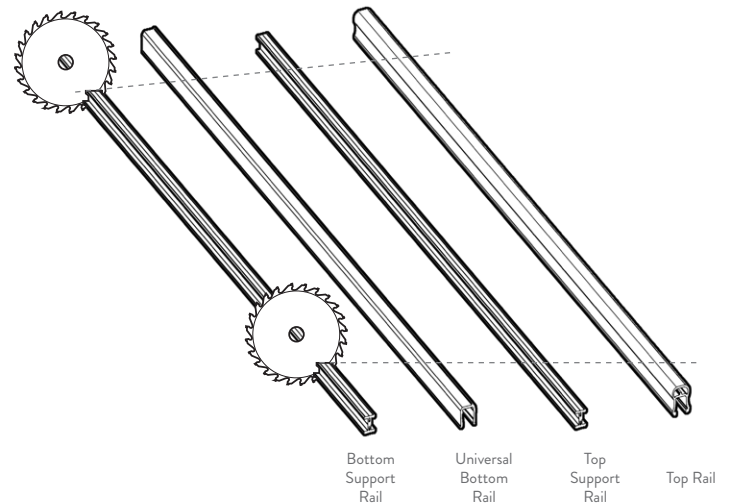

4

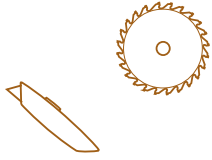

TRIM GLASS CHANNELS AND GASKETS

- Using lengths in Step 3 as a reference, measure and cut Top and Bottom Glass Channels, as well as both Rubber Gaskets at appropriate angle.

! Glass Channels must be at least 4" shorter than rail.

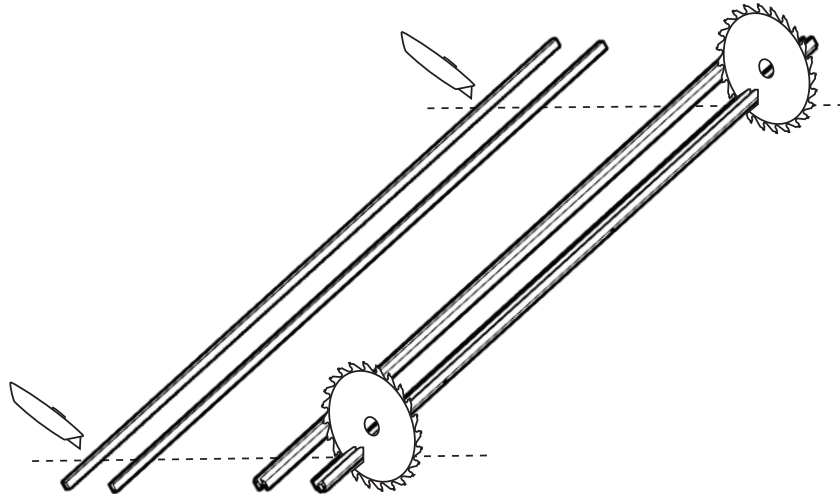

5



INSTALL BOTTOM SUPPORT RAIL

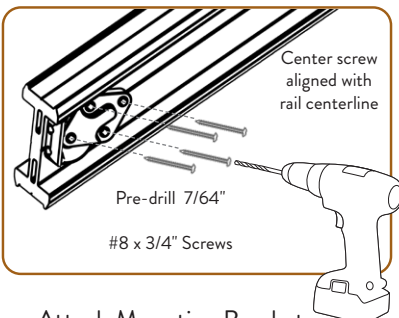

- Attach Mounting Brackets to Top AND Bottom Support Rails.

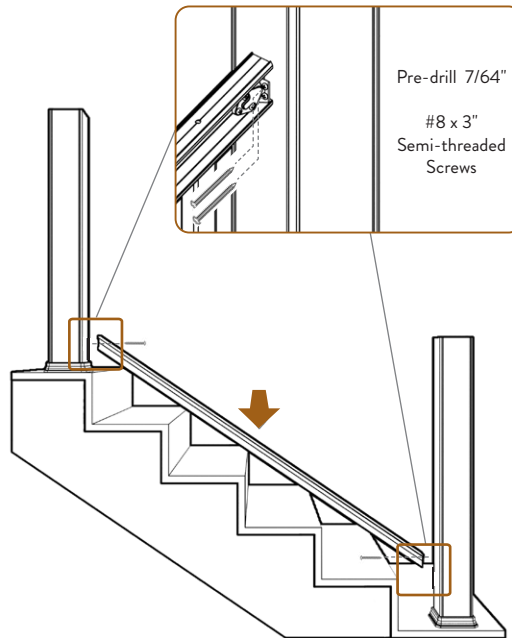

- Position Bottom Support Rail on the center of the posts and secure Mounting Brackets to posts.

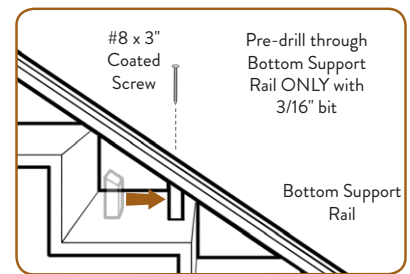

- Trim Foot Block and wedge under Support Rail & Attach.

6



ASSEMBLE LOWER RAIL SECTION

- Place Universal Bottom Rail over Bottom Support Rail.
- Install Bottom Glass Channel utilizing pre-drilled holes.

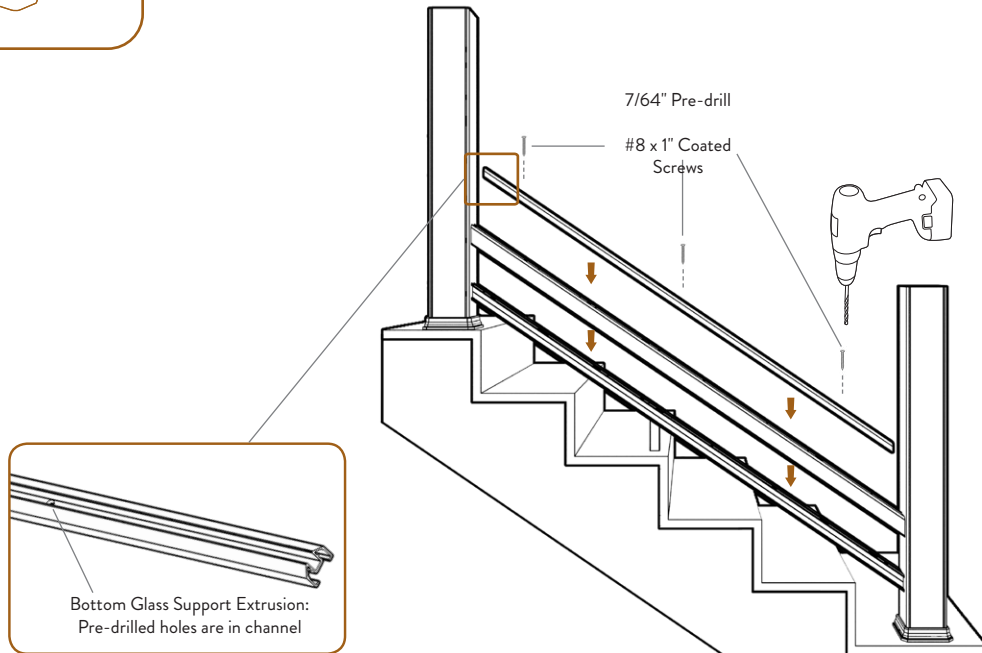

7

ATTACH LOWER GASKET AND INSTALL GLASS PANEL

- Apply Rubber Gasket to bottom of Glass Panel first.
- Set panel/gasket assembly into Bottom Glass Channel.

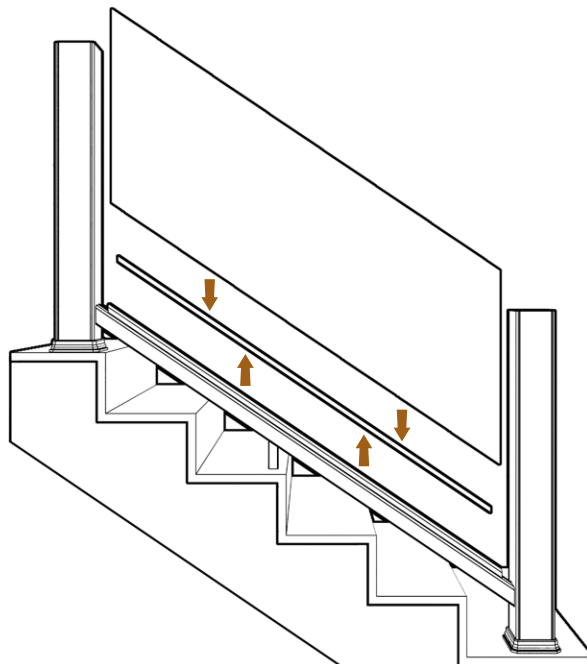

8

INSTALL TOP GASKET AND TOP GLASS CHANNEL

- Place Rubber Gasket on top of glass panel.
- Fit Top Glass Channel onto glass panel assembly.

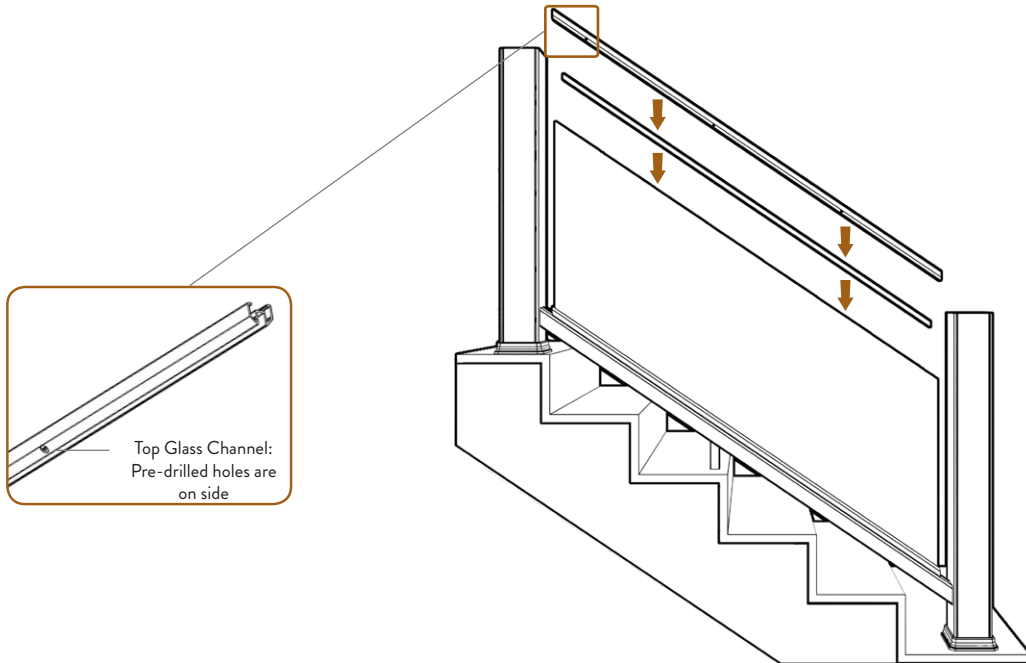

9

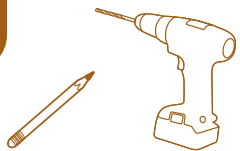

INSTALL TOP SUPPORT RAIL

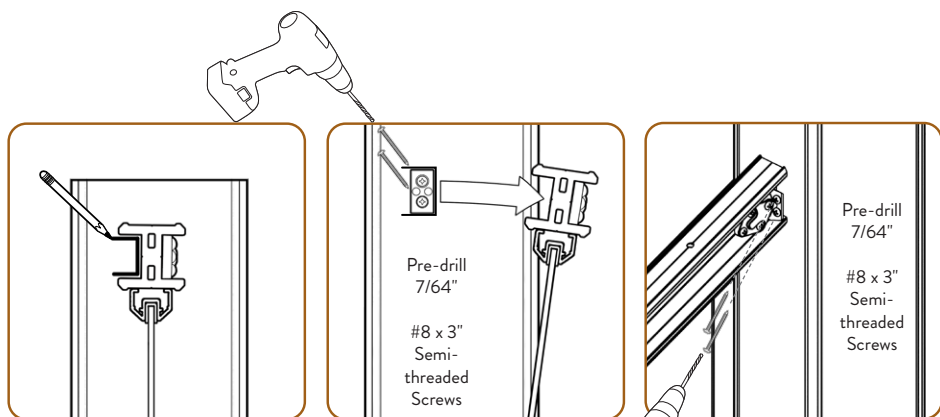
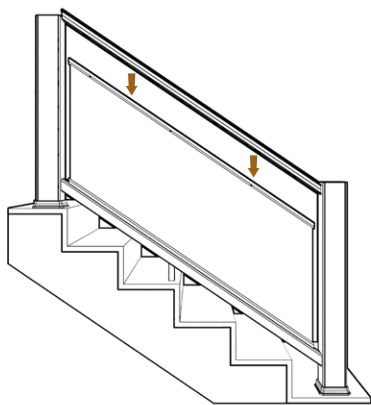

- Mark Ends of Top Support Rail.

- Rotate Rail assembly out of way to fasten Support Block

- Secure Mounting Brackets to Posts.

10

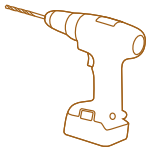

INSTALL TOP RAIL AND POST CAPS

- Attach Top Rail using 3" coated screws driving screws up through Top Glass Channel into Top Rail
- Attach Post caps using exterior grade caulk applied to the underside of the cap.

3/16" Pre-drill through existing holes in Top Glass Channel.

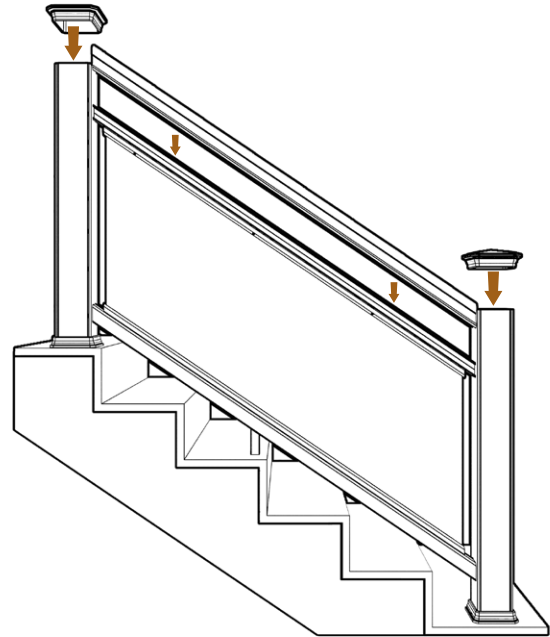
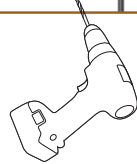
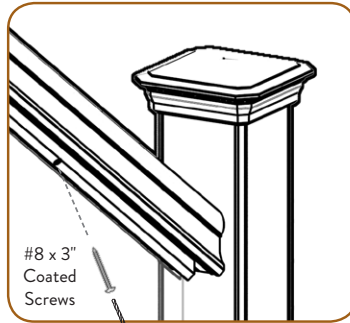

Screws must be 3" to attach the Top Rail on stair sections.

INSTALLING RESERVE RAIL OVER-THE-POST

RESERVE RAIL SERIES RAILING

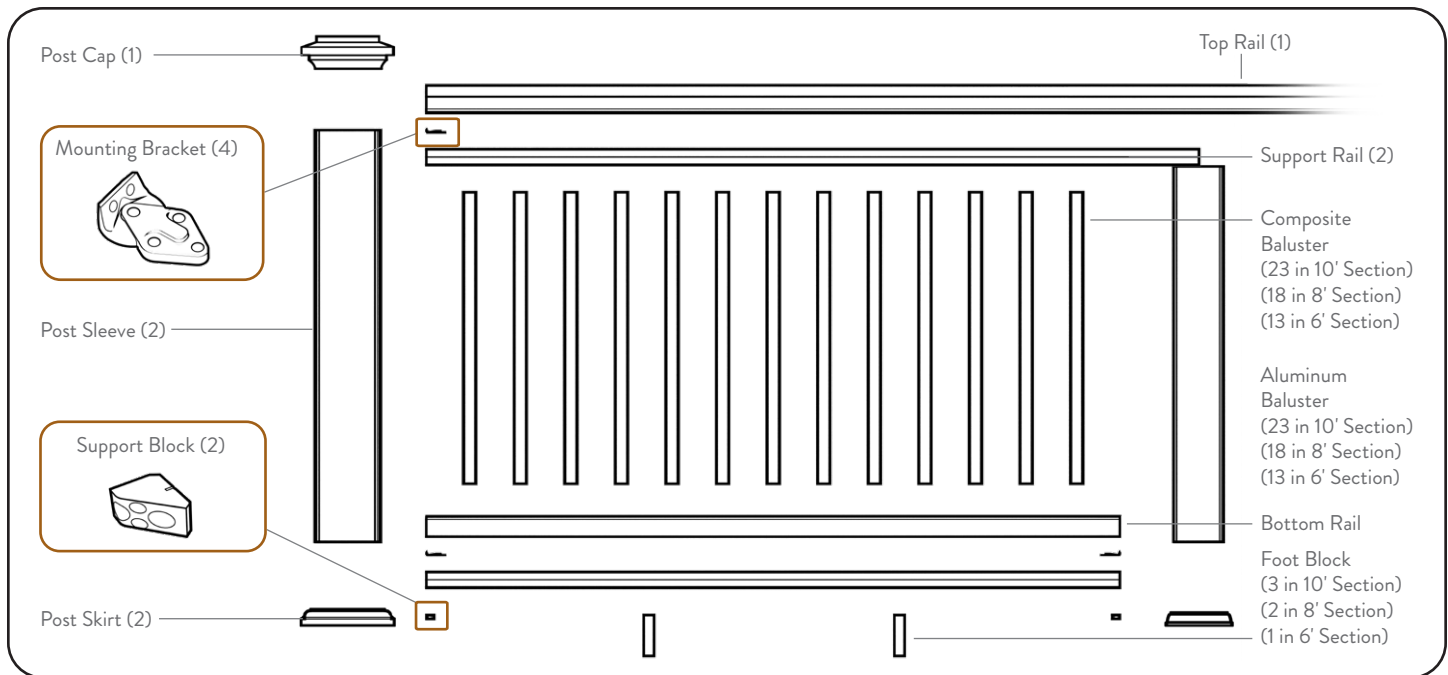

⚠️ IMPORTANT NOTES:

- TimberTech Reserve Rail Packs are available in 6', 8', and 10' lengths.
- TimberTech Reserve Top Rail is available in 6', 8', 10', 12', and 16' lengths.
- Visit <https://www.timbertech.com/installation-help> to view TimberTech installation videos.
- Consult your local building codes for guard and handrail requirements.
- Measurements are from center to center of post. Rails are produced in 6', 8', and 10' lengths to allow for finished end cuts and angles.
- Determine how many 6', 8', and 10' TimberTech rail sections you need and check to be sure you have all the components (and quantities) listed in the chart shown to the right.
- TimberTech Rails 6', 8', and 10' rails are designed not to exceed 6', 8', and 10' center of post to center of post, respectively.
- TimberTech Reserve Rail can be installed Over the Post on level applications only.
- 4x4 lumber posts must be installed plumb and level with each other.
- Cut slowly, using a thin kerf, finish saw blade to avoid chipping.
- Read instructions completely to get an understanding of how the product goes together and how each piece affects the other.
- For all applications, a structural post must be used inside our Post Sleeve.
- Compatible with all Classic Composite Series Railing Infills.

TOOLS REQUIRED

- Miter Saw
- 7/64" Drill Bit
- Measuring Tape
- Drill
- 3/16" Drill Bit
- Caulk Gun

COMPONENT DIMENSIONS

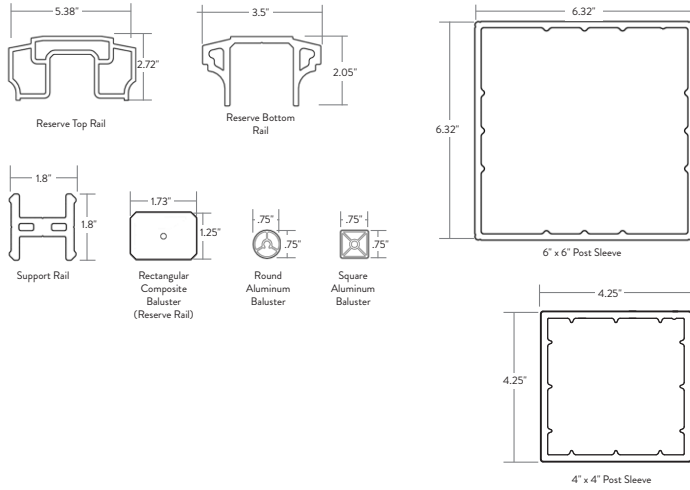

MEASURING YOUR RAILING AREA

- Measurements are from center to center of the posts. Rails are produced in 10', 8' and 6' to allow for finished end cuts and angles.
- Determine how many 10', 8' and 6' TimberTech Rail Sections you need and check to be sure you have all the components (and quantities) listed in the chart shown.

COMPONENTS NEEDED FOR INSTALLING ONE TIMBERTECH RESERVE RAIL OVER-THE-POST SECTION

Components available separately for mix-and-match rail systems	Reserve Top Rail	1 - Top Rail (6', 8', 10', 12', and 16' lengths)			
	Reserve Rail Pack	1 - Bottom Rail 2 - Support Rails (1 - Aluminum Top Support Rail for 10') Hardware Mounting Kit Support Block Mounting Templates Foot Blocks - 1 in 6' Packs, - 2 in 8' Packs, - 3 in 10' Packs			
	Baluster Pack	<table style="width: 100%; border: none;"> <tr> <td style="width: 50%; vertical-align: top;"> Composite Balusters - 18 Balusters per Pack (23 required per 10' section) (18 required per 8' section) (13 required per 6' section) - 29" for 36" Railing - 31" for 36" Railing (with less than 2" gap between deck & Bottom Rail) - 35" for 42" Railing - 37" for 42" Railing (with less than 2" gap between deck & Bottom Rail) </td> <td style="width: 50%; vertical-align: top;"> Aluminum Balusters - 20 Balusters per Pack (25 required per 10' section) (20 required per 8' section) (15 required per 6' section) - 29" for 36" Railing - 31" for 36" Railing (with less than 2" gap between deck & Bottom Rail) - 35" for 42" Railing - 37" for 42" Railing (with less than 2" gap between deck & Bottom Rail) </td> </tr> <tr> <td style="vertical-align: top;"> Baluster Screw Kit 18 - #8x2" Screws 18 - #8x3" Screws </td> <td style="vertical-align: top;"> Baluster Screw Kit 20 - #8x2" Screws 20 - #8x3" Screws </td> </tr> </table>	Composite Balusters - 18 Balusters per Pack (23 required per 10' section) (18 required per 8' section) (13 required per 6' section) - 29" for 36" Railing - 31" for 36" Railing (with less than 2" gap between deck & Bottom Rail) - 35" for 42" Railing - 37" for 42" Railing (with less than 2" gap between deck & Bottom Rail)	Aluminum Balusters - 20 Balusters per Pack (25 required per 10' section) (20 required per 8' section) (15 required per 6' section) - 29" for 36" Railing - 31" for 36" Railing (with less than 2" gap between deck & Bottom Rail) - 35" for 42" Railing - 37" for 42" Railing (with less than 2" gap between deck & Bottom Rail)	Baluster Screw Kit 18 - #8x2" Screws 18 - #8x3" Screws
Composite Balusters - 18 Balusters per Pack (23 required per 10' section) (18 required per 8' section) (13 required per 6' section) - 29" for 36" Railing - 31" for 36" Railing (with less than 2" gap between deck & Bottom Rail) - 35" for 42" Railing - 37" for 42" Railing (with less than 2" gap between deck & Bottom Rail)	Aluminum Balusters - 20 Balusters per Pack (25 required per 10' section) (20 required per 8' section) (15 required per 6' section) - 29" for 36" Railing - 31" for 36" Railing (with less than 2" gap between deck & Bottom Rail) - 35" for 42" Railing - 37" for 42" Railing (with less than 2" gap between deck & Bottom Rail)				
Baluster Screw Kit 18 - #8x2" Screws 18 - #8x3" Screws	Baluster Screw Kit 20 - #8x2" Screws 20 - #8x3" Screws				
Hardware included in Hardware Mounting Kits	4 - Mounting Brackets 2 - Support Blocks 16 - #8 x 3/4" Screws 6 - #8 x 1 5/8" Screws 6 - #8 x 2 5/8" Screws (Stairs Only) 6 - #8 x 3" Screws 12 - #8 x 3" Semi-threaded Screws T20 Driver Bit				
Additional Components Needed for Each System	4" Post Sleeves 4" Post Skirts 6" Post Caps (Only required for 6" Post Sleeves in the Reserve Over-the-Post Application) 6" Post Sleeves 6" Post Skirts				

INSTALLING RESERVE RAIL OVER-THE-POST

RESERVE RAIL SERIES RAILING

1

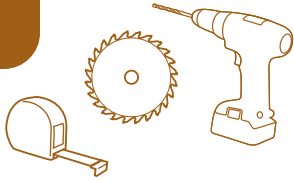

INSTALL POST SLEEVES

- Slide Post Sleeve and Post Skirt over post (do not force).
- Ensure posts are square and plumb. Shim as needed to plumb.
- Cut 6" Post Sleeve and corresponding 6"x6" Post to desired height.
- Cut 4" Post Sleeve and corresponding 4"x4" post to 33 3/4" (test fit railing to ensure height is exact).
- Center of 6" Post Sleeve and 4" Post Sleeve must be aligned when installed. This will require additional blocking for the 4"x4" post (5/4 blocking in most cases).

 39" above deck surface is optimal for 36" railing heights.

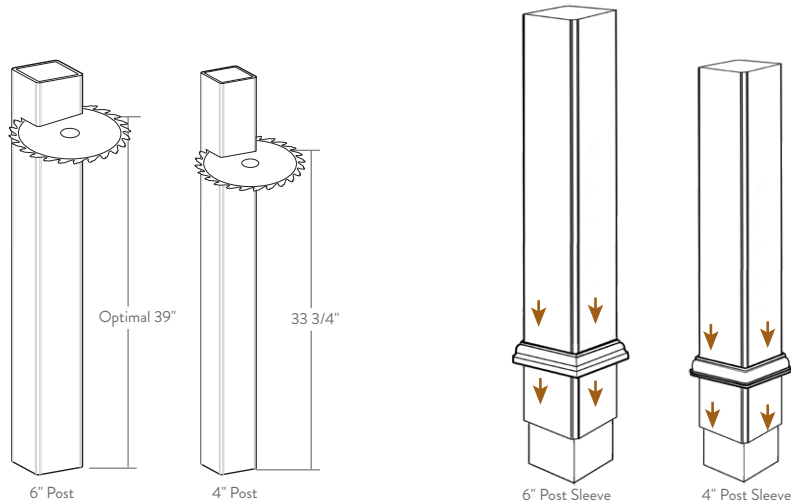

2

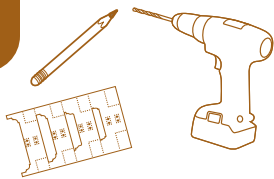

INSTALL LOWER SUPPORT BLOCK

- Position the 6"x6" template at the bottom of the 6" Post Sleeve, above the Post Skirt.
- Position the 4"x4" template at the bottom of the 4" Post Sleeve above the Post Skirt.

 If you do not have a the template, position the top of the Support Block 4" above the deck.

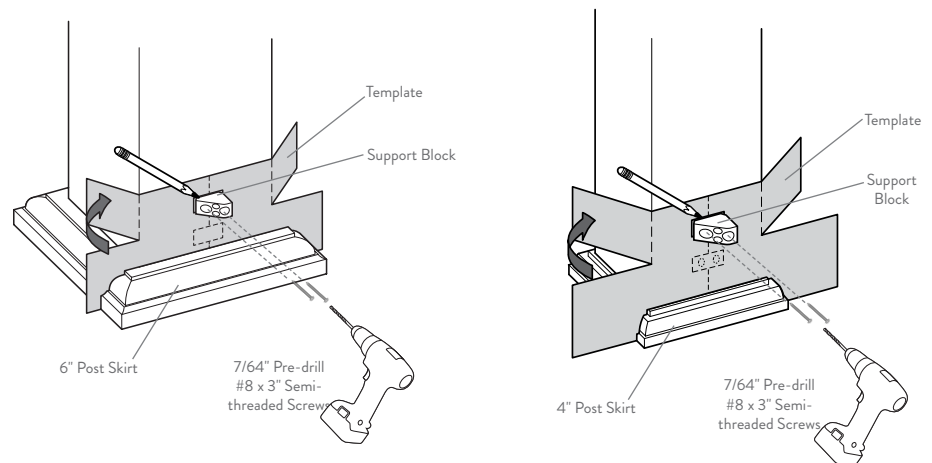

3

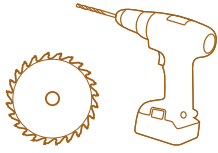

CUT AND ASSEMBLE BOTTOM SUPPORT RAIL

- Cut the Bottom Support Rail to length.
- Add support blocks as required.
- Attach brackets.



For sections up to 6': Place one Foot Block in the center of the rail.

For sections 6' to 8': Space two Foot Blocks approximately at 1/3 intervals on the rail.

For sections 8' to 10': Space three Foot Blocks approximately at 1/4 intervals on the rail.

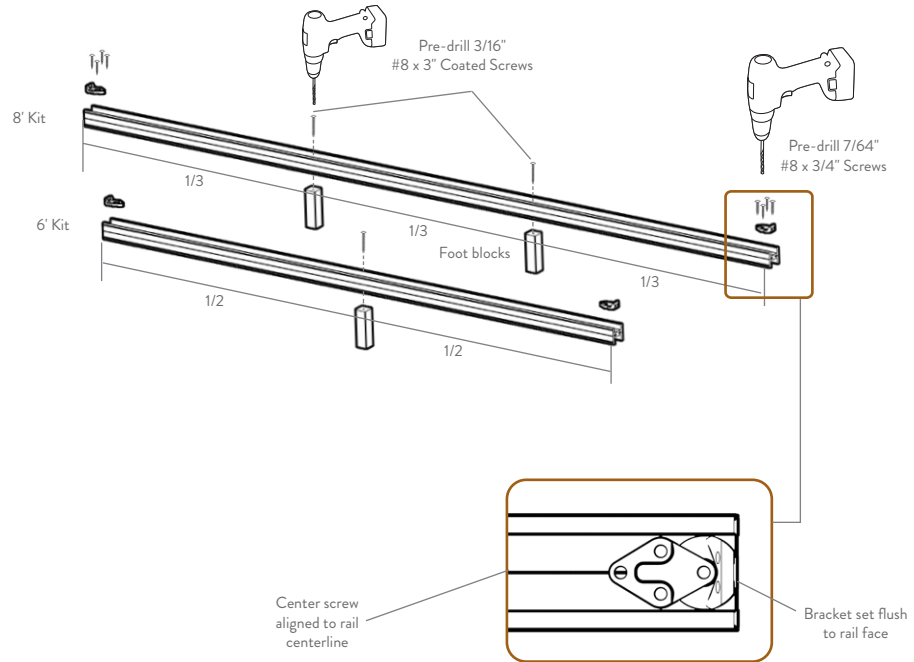

4

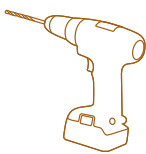

INSTALL BOTTOM SUPPORT RAIL

- Position Bottom Support Rail assembly onto Support Blocks.
- Pre-drill holes into post sleeves only.
- Attach brackets with green coated screws.

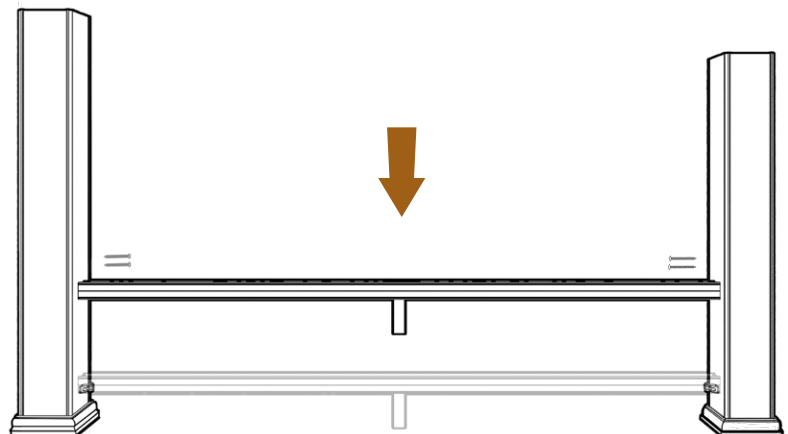
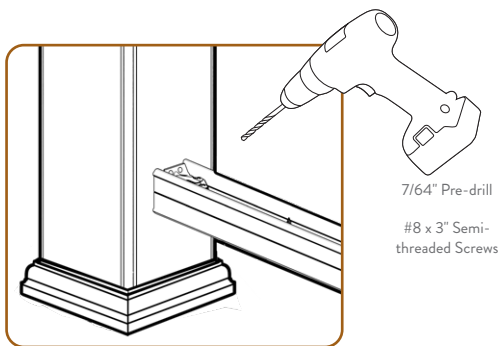

5

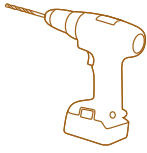

SPACE BALUSTER AND TRIM RAILS

- Measure distance between the posts at the Bottom Support Rail.
- Transfer measurement to Bottom Rail and center either on a pre-drilled hole or between two pre-drilled holes.
- Cut Bottom Rail to length.
- Align holes and cut the Top Support Rail to be 2 1/8" longer than the Bottom Rail.



The space between the end baluster and post can not exceed 4".

Centering Balusters

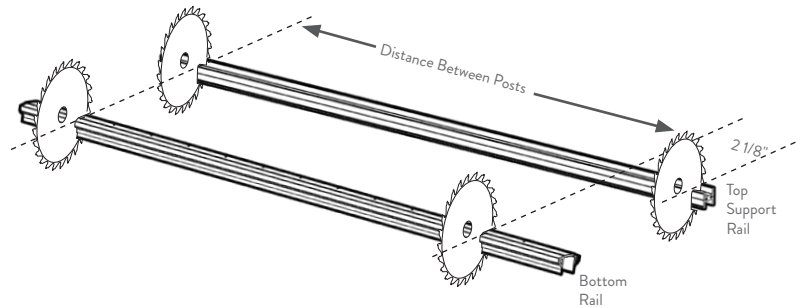
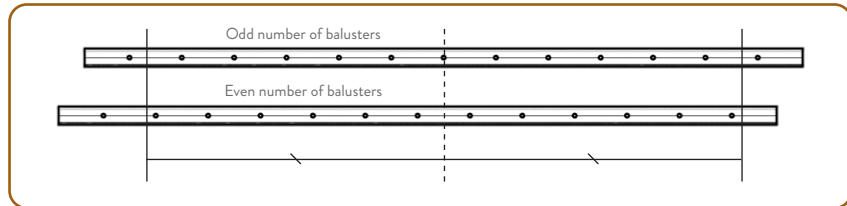

6

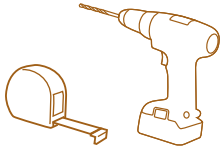

ASSEMBLE BALUSTER SECTION

- Attach a Mounting Bracket to one side of the Top Support Rail (outlined in Step 3), this will be attached to the 6" Post.
- On the side that will run over the 4" Post Sleeve, pre-drill the Top Support Rail with two holes using a 3/16" drill bit at a 10-15 degree angle. These holes should be separated by about 1/2" and should start 1" away from the end of the rail.



For 10' rail sections utilizing aluminum support rail, when attaching Mounting Brackets at each end of the Top Support Rail, pre-drill using a 9/64" drill bit (instead of 7/64" bit).

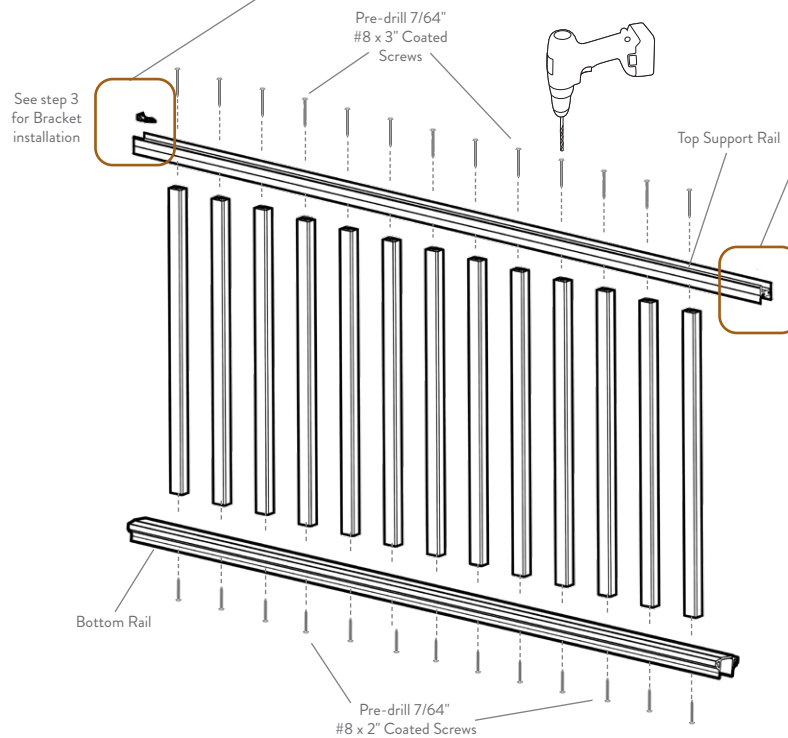
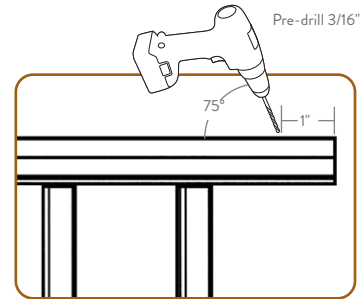
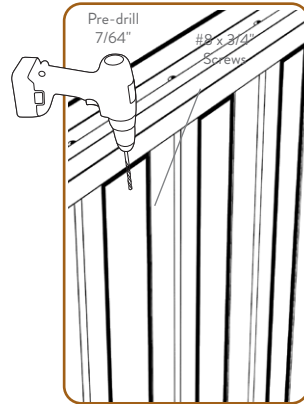

INSTALLING RESERVE RAIL OVER-THE-POST

RESERVE RAIL SERIES RAILING

7



INSTALL RAIL ASSEMBLY

- Align Top Support Rail to center of Posts.
- Use the 3" Green Screws, provided in the Universal Hardware Kit to fasten the Top Support Rail to the 4"x4" post.
- The top of the 4"x4" post, 4" Post Sleeve, and the bottom of the Support Rail should line up to the same height. Test fit railing prior to making final cuts on 4"x4" post and 4" Post Sleeve to ensure these heights are aligned.

7/64" Pre-drill
#8 x 3"
Coated Green
Screws

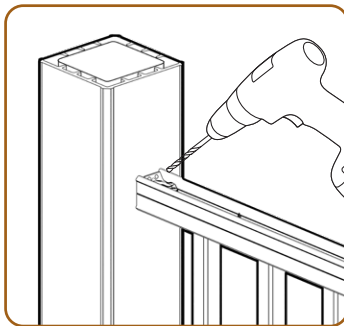

Align to center of post

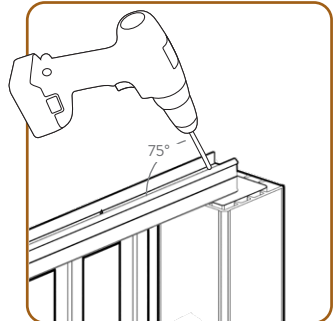
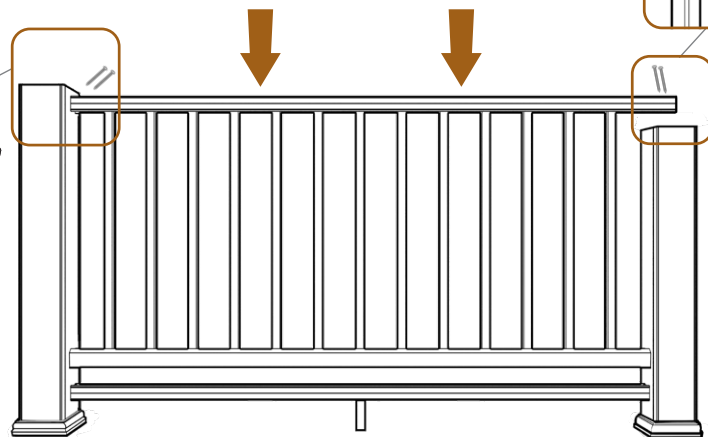

8

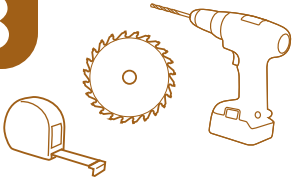

INSTALL TOP RAIL AND POST CAP

- Measure and cut the Top Rail to length. Trim both ends for a clean cut.
- Attach Post Cap using exterior grade caulk applied to the underside of the Cap.

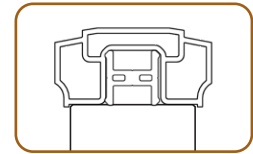

Side View of Over the Post Application

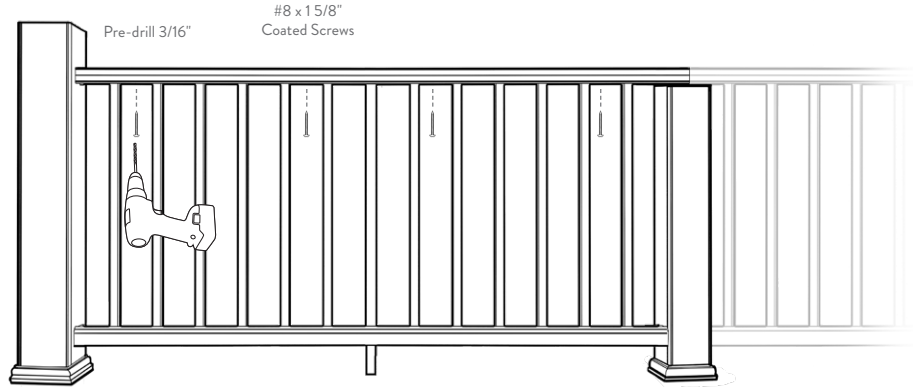
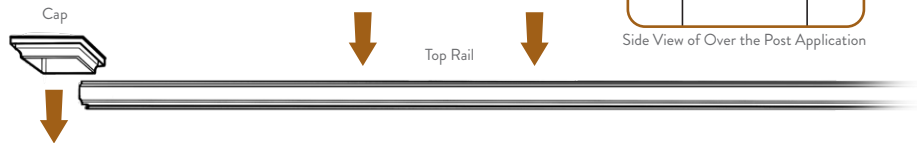
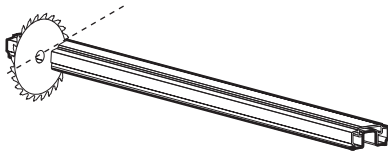

Caution: Screws must be 1 5/8" so they won't go through the Top Rail on straight rail sections.

