



# TIMBERTECH CLASSIC COMPOSITE SERIES AND RESERVE RAILING INSTALL GUIDE

Installing TimberTech Reserve Rail Over the Post.....3  
Notes .....11

TimberTech Reserve Rail can be installed with a continuous Top Rail in up to 16' lengths, measured from the center of the end posts. These applications require the use of a 4" Post Sleeve, 4" Post Skirt and a 4" x4" Post as an intermediate post, as well as unique fastening procedures. This Install Guide details these unique procedures.

#### IMPORTANT NOTES:

- Please read all instructions completely before starting any part of the installation. Always make sure to visit [www.TimberTech.com](http://www.TimberTech.com) to ensure you are viewing the most current installation instructions, care and cleaning, technical information and more.
- TimberTech Railing should be installed using the same good building principles used to install wood or composite railing and in accordance with the local building codes and the installation guidelines included below.
- AZEK Co. LLC accepts no liability or responsibility for the improper installation of this product.
- TimberTech Railing may not be suitable for every application and it is the sole responsibility of the installer to be sure that TimberTech Railing is fit for the intended use. Since all installations are unique, it is also the installer's responsibility to determine specific requirements in regards to each Rail application.
- AZEK Co. LLC recommends that all applications be reviewed by a licensed architect, engineer or local building official before installation. If you have any questions or need further assistance, please call AZEK Customer Service at 877-ASK-AZEK (877-275-2935) or visit our website at [www.TimberTech.com](http://www.TimberTech.com).
- TimberTech Railing is tested as a whole system and should be used that way. It is not intended to be used in conjunction with other railing systems or fasteners.
- The following Installation Guidelines are applicable for installation of TimberTech Classic Composite Series and TimberTech Reserve Rail Systems.
- **IMPORTANT:** Make sure the DRIVE TOOL/DRILL is configured or set to use the SCREW setting when driving and/or tightening all FASTENERS. It is very Important not to overdrive fasteners. The use of Impact type drill drivers can increase the risk of overdriving fasteners.
- **SAFETY:** Always wear goggles when handling, cutting, drilling and fastening materials.
- Failure to install this product in accordance with applicable building codes and TimberTech's written Railing Install Guide may lead to personal injury, affect rail system performance and void the product warranty.
- The buildup or generation of static electricity is a naturally occurring phenomenon in many plastic based products such as carpeting, upholstery, and clothing, and can occur on alternative decking under certain environmental conditions. This static electricity can discharge once contact is made with hardware, railing, or other conductors of electricity.



Find install videos, written instructions and a chat link at <https://www.timbertech.com/installation-help>.

**NOTE:** IF INSTALLING POST LIGHTING, WIRING MUST BE INSTALLED PRIOR TO SECURING POSTS TO DECK/STAIR SURFACE AND INSTALLING TOP RAILS.

It is the responsibility of the installer to meet all local code requirements and obtain all required building permits. The installer should determine and implement appropriate installation techniques for each installation situation. The AZEK Company or its reseller shall not be held responsible for improper or unsafe installations.

# INSTALLING RESERVE RAIL OVER-THE-POST

## RESERVE RAIL SERIES RAILING

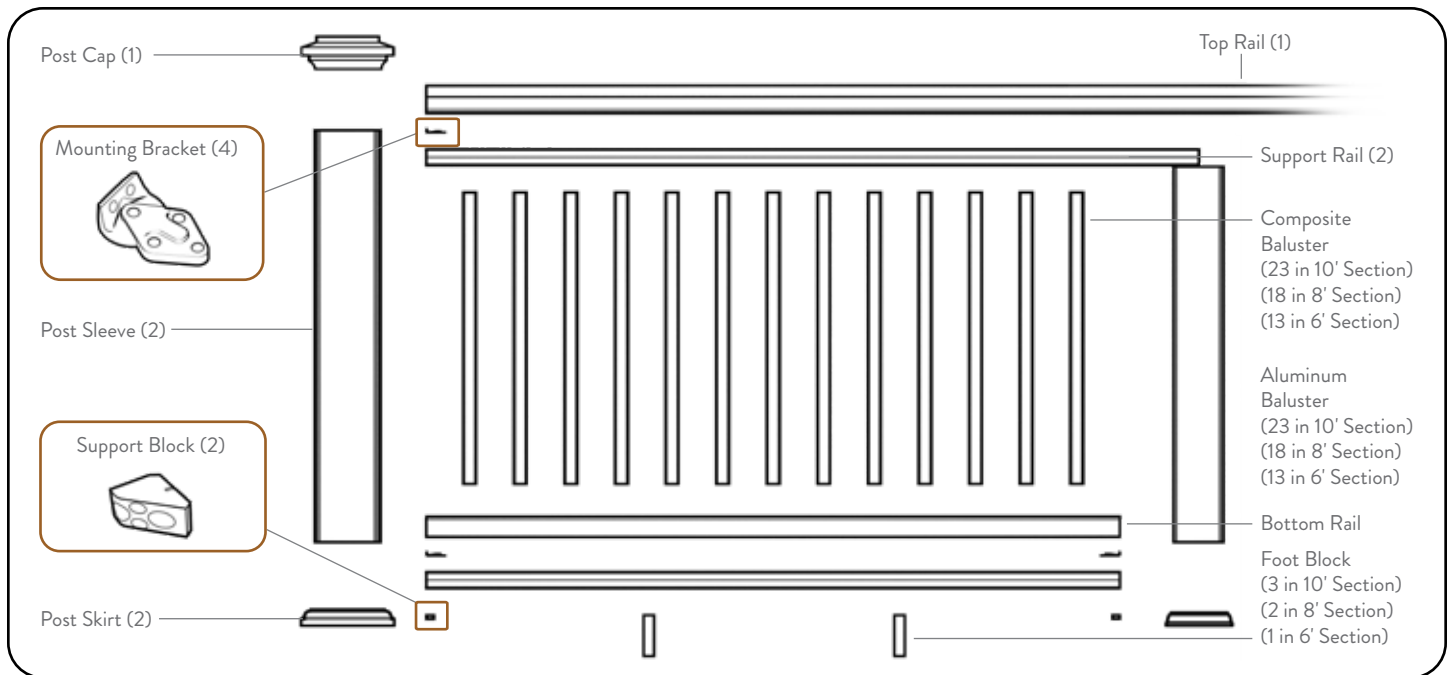

### ⚠ IMPORTANT NOTES:

- TimberTech Reserve Rail Packs are available in 6', 8', and 10' lengths.
- TimberTech Reserve Top Rail is available in 6', 8', 10', 12', and 16' lengths.
- Visit <https://www.timbertech.com/installation-help> to view TimberTech installation videos.
- Consult your local building codes for guard and handrail requirements.
- Measurements are from center to center of post. Rails are produced in 6', 8', and 10' lengths to allow for finished end cuts and angles.
- Determine how many 6', 8', and 10' TimberTech rail sections you need and check to be sure you have all the components (and quantities) listed in the chart shown to the right.
- TimberTech Rails 6', 8', and 10' rails are designed not to exceed 6', 8', and 10' center of post to center of post, respectively.
- TimberTech Reserve Rail can be installed Over the Post on level applications only.
- 4x4 lumber posts must be installed plumb and level with each other.
- Cut slowly, using a thin kerf, finish saw blade to avoid chipping.
- Read instructions completely to get an understanding of how the product goes together and how each piece affects the other.
- For all applications, a structural post must be used inside our Post Sleeve.
- Compatible with all Classic Composite Series Railing Infills.

### TOOLS REQUIRED

- Miter Saw
- 7/64" Drill Bit
- Measuring Tape
- Drill
- 3/16" Drill Bit
- Caulk Gun

### COMPONENT DIMENSIONS

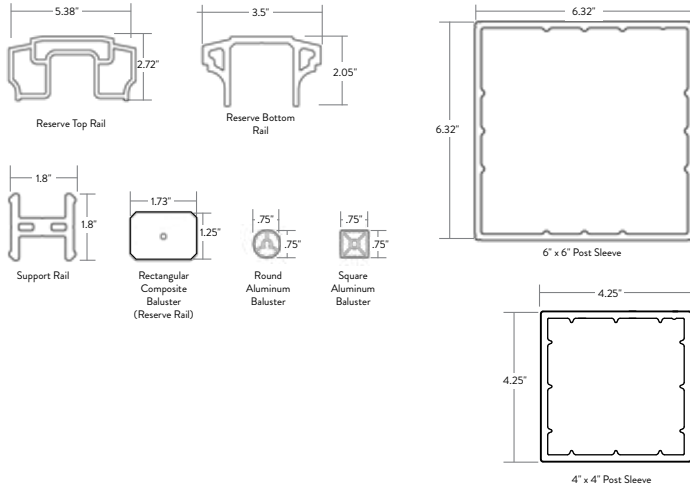

### MEASURING YOUR RAILING AREA

- Measurements are from center to center of the posts. Rails are produced in 10', 8' and 6' to allow for finished end cuts and angles.
- Determine how many 10', 8' and 6' TimberTech Rail Sections you need and check to be sure you have all the components (and quantities) listed in the chart shown.

### COMPONENTS NEEDED FOR INSTALLING ONE TIMBERTECH RESERVE RAIL OVER-THE-POST SECTION

<b>Components available separately for mix-and-match rail systems</b>	<b>Reserve Top Rail</b>	<b>1 - Top Rail</b> - 6', 8', 10', 12', and 16' lengths (Sold separately for safe efficient shipping and over the post installs)			
	<b>Reserve Rail Pack</b>	<b>1 - Bottom Rail</b> <b>2 - Support Rails</b> (1 - Aluminum Top Support Rail for 10') <b>Hardware Mounting Kit</b> <b>Support Block Mounting Templates</b> <b>Foot Blocks</b> (1 in 6' Packs, 2 in 8' Packs, 3 in 10' Packs)			
	<b>Baluster Pack</b>	<table style="width: 100%; border: none;"> <tr> <td style="width: 50%; vertical-align: top;"> <b>Composite Balusters</b>            - 18 Balusters per Pack (23 required per 10' section)            (18 required per 8' section)            (13 required per 6' section)            - 29" for 36" Railing            - 31" for 36" Railing (with less than 2" gap between deck &amp; Bottom Rail)            - 35" for 42" Railing            - 37" for 42" Railing (with less than 2" gap between deck &amp; Bottom Rail)         </td> <td style="width: 50%; vertical-align: top;"> <b>Aluminum Balusters</b>            - 20 Balusters per Pack (25 required per 10' section)            (20 required per 8' section)            (15 required per 6' section)            - 29" for 36" Railing            - 31" for 36" Railing (with less than 2" gap between deck &amp; Bottom Rail)            - 35" for 42" Railing            - 37" for 42" Railing (with less than 2" gap between deck &amp; Bottom Rail)         </td> </tr> <tr> <td style="vertical-align: top;"> <b>Baluster Screw Kit</b>            18 - #8x2" Screws            18 - #8x3" Screws         </td> <td style="vertical-align: top;"> <b>Baluster Screw Kit</b>            20 - #8x2" Screws            20 - #8x3" Screws         </td> </tr> </table>	<b>Composite Balusters</b> - 18 Balusters per Pack (23 required per 10' section) (18 required per 8' section) (13 required per 6' section) - 29" for 36" Railing - 31" for 36" Railing (with less than 2" gap between deck & Bottom Rail) - 35" for 42" Railing - 37" for 42" Railing (with less than 2" gap between deck & Bottom Rail)	<b>Aluminum Balusters</b> - 20 Balusters per Pack (25 required per 10' section) (20 required per 8' section) (15 required per 6' section) - 29" for 36" Railing - 31" for 36" Railing (with less than 2" gap between deck & Bottom Rail) - 35" for 42" Railing - 37" for 42" Railing (with less than 2" gap between deck & Bottom Rail)	<b>Baluster Screw Kit</b> 18 - #8x2" Screws 18 - #8x3" Screws
<b>Composite Balusters</b> - 18 Balusters per Pack (23 required per 10' section) (18 required per 8' section) (13 required per 6' section) - 29" for 36" Railing - 31" for 36" Railing (with less than 2" gap between deck & Bottom Rail) - 35" for 42" Railing - 37" for 42" Railing (with less than 2" gap between deck & Bottom Rail)	<b>Aluminum Balusters</b> - 20 Balusters per Pack (25 required per 10' section) (20 required per 8' section) (15 required per 6' section) - 29" for 36" Railing - 31" for 36" Railing (with less than 2" gap between deck & Bottom Rail) - 35" for 42" Railing - 37" for 42" Railing (with less than 2" gap between deck & Bottom Rail)				
<b>Baluster Screw Kit</b> 18 - #8x2" Screws 18 - #8x3" Screws	<b>Baluster Screw Kit</b> 20 - #8x2" Screws 20 - #8x3" Screws				
<b>Hardware included in Hardware Mounting Kits</b>	<b>4 - Mounting Brackets</b> <b>2 - Support Blocks</b> <b>16 - #8 x 3/4" Screws</b> <b>6 - #8 x 1 5/8" Screws</b> <b>6 - #8 x 2 5/8" Screws</b> (Stairs Only) <b>6 - #8 x 3" Screws</b> <b>12 - #8 x 3" Semi-threaded Screws</b> <b>T20 Driver Bit</b>				
<b>Additional Components Needed for Each System</b>	<b>4" Post Sleeves</b> <b>4" Post Skirts</b> <b>6" Post Caps</b> (Only required for 6" Post Sleeves in the Reserve Over-the-Post Application) <b>6" Post Sleeves</b> <b>6" Post Skirts</b>				

# INSTALLING RESERVE RAIL OVER-THE-POST

## RESERVE RAIL SERIES RAILING



1

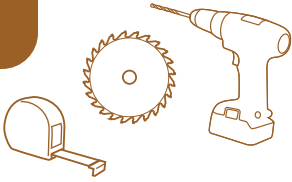

### INSTALL POST SLEEVES

- Slide Post Sleeve and Post Skirt over post (do not force).
- Ensure posts are square and plumb. Shim as needed to plumb.
- Cut 6" Post Sleeve and corresponding 6"x6" Post to desired height.
- Cut 4" Post Sleeve and corresponding 4"x4" post to 33 3/4" (test fit railing to ensure height is exact).
- Center of 6" Post Sleeve and 4" Post Sleeve must be aligned when installed. This will require additional blocking for the 4"x4" post (5/4 blocking in most cases).

**!** 39" above deck surface is optimal for 36" railing heights.

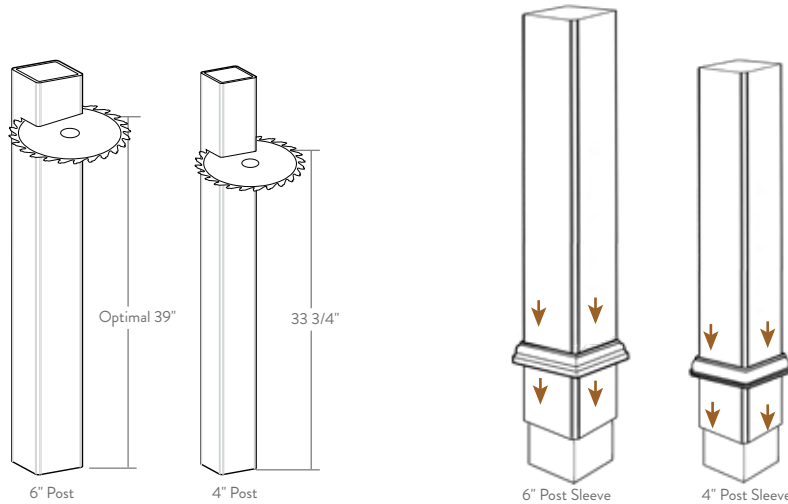

2

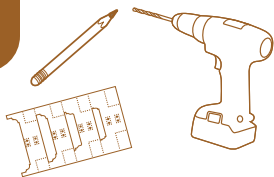

### INSTALL LOWER SUPPORT BLOCK

- Position the 6"x6" template at the bottom of the 6" Post Sleeve, above the Post Skirt.
- Position the 4"x4" template at the bottom of the 4" Post Sleeve above the Post Skirt.

**!** If you do not have a the template, position the top of the Support Block 4" above the deck.

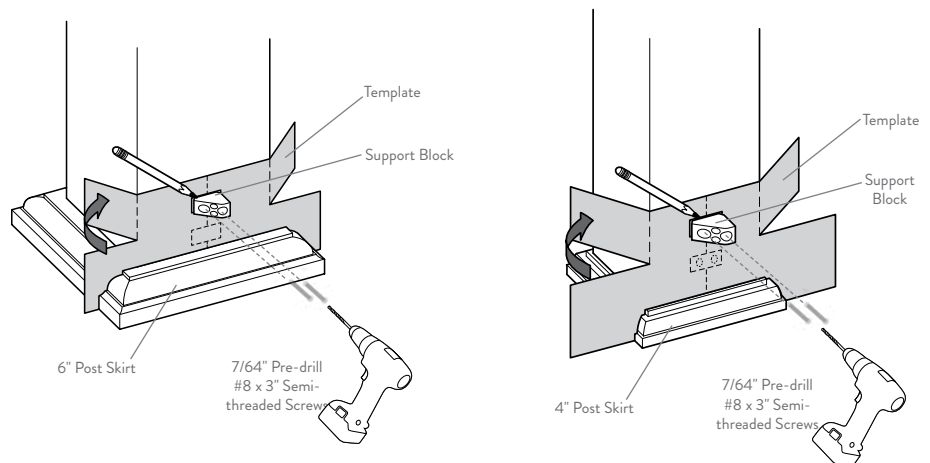

**3**

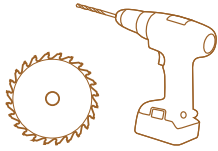

**CUT AND ASSEMBLE BOTTOM SUPPORT RAIL**

- Cut the Bottom Support Rail to length.
- Add support blocks as required.
- Attach brackets.



For sections up to 6': Place one Foot Block in the center of the rail.

For sections 6' to 8': Space two Foot Blocks approximately at 1/3 intervals on the rail.

For sections 8' to 10': Space three Foot Blocks approximately at 1/4 intervals on the rail.

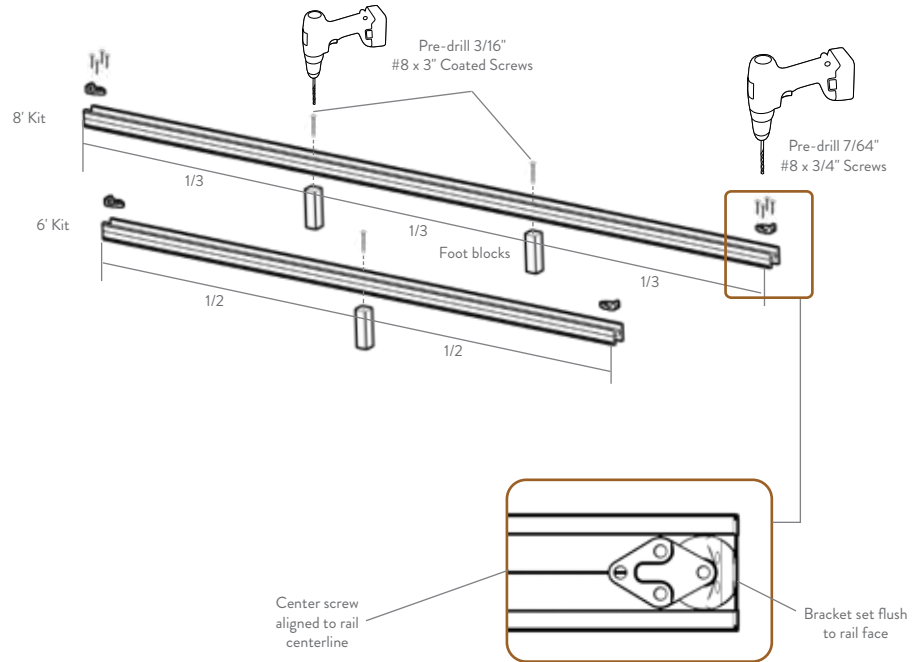

**4**

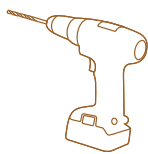

**INSTALL BOTTOM SUPPORT RAIL**

- Position Bottom Support Rail assembly onto Support Blocks.
- Pre-drill holes into post sleeves only.
- Attach brackets with green coated screws.

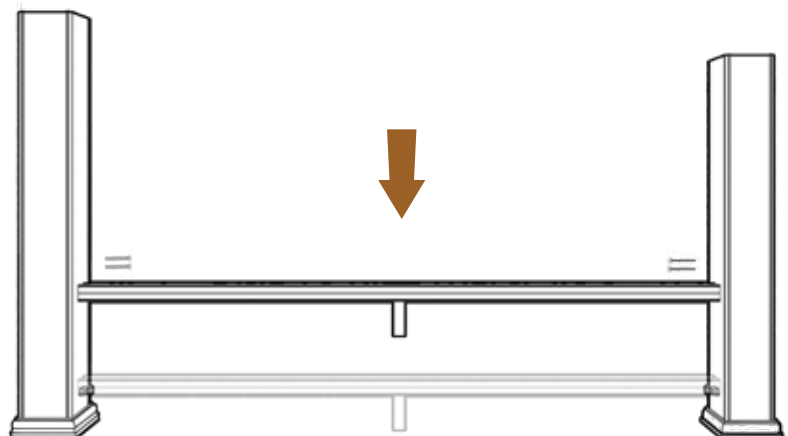
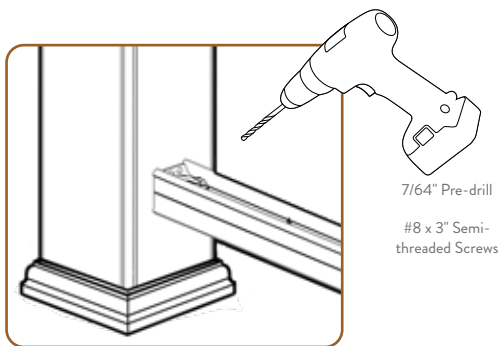

5



### SPACE BALUSTER AND TRIM RAILS

- Measure distance between the posts at the Bottom Support Rail.
- Transfer measurement to Bottom Rail and center either on a pre-drilled hole or between two pre-drilled holes.
- Cut Bottom Rail to length.
- Align holes and cut the Top Support Rail to be 2 1/8" longer than the Bottom Rail.



The space between the end baluster and post can not exceed 4".

Centering Balusters

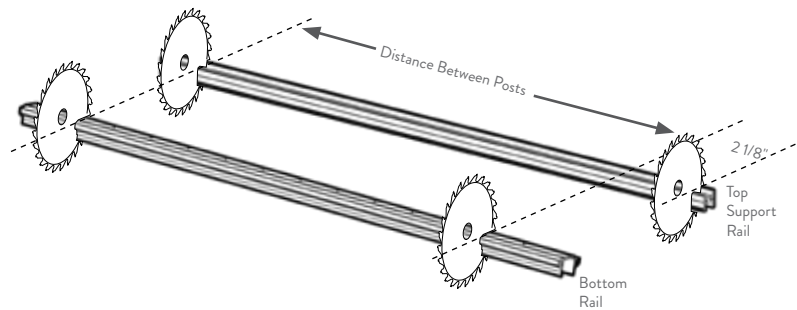
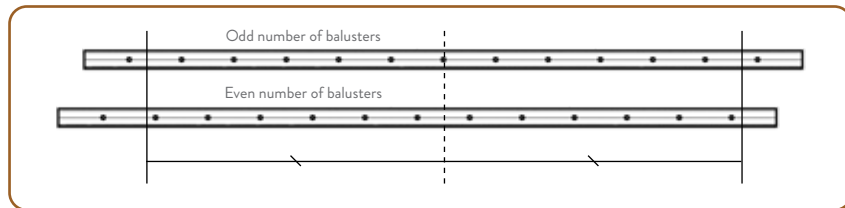

6

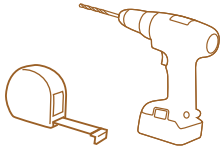

**ASSEMBLE BALUSTER SECTION**

- Attach a Mounting Bracket to one side of the Top Support Rail (outlined in Step 3), this will be attached to the 6" Post.
- On the side that will run over the 4" Post Sleeve, pre-drill the Top Support Rail with two holes using a 3/16" drill bit at a 10-15 degree angle. These holes should be separated by about 1/2" and should start 1" away from the end of the rail.



For 10' rail sections utilizing aluminum support rail, when attaching Mounting Brackets at each end of the Top Support Rail, pre-drill using a 9/64" drill bit (instead of 7/64" bit).

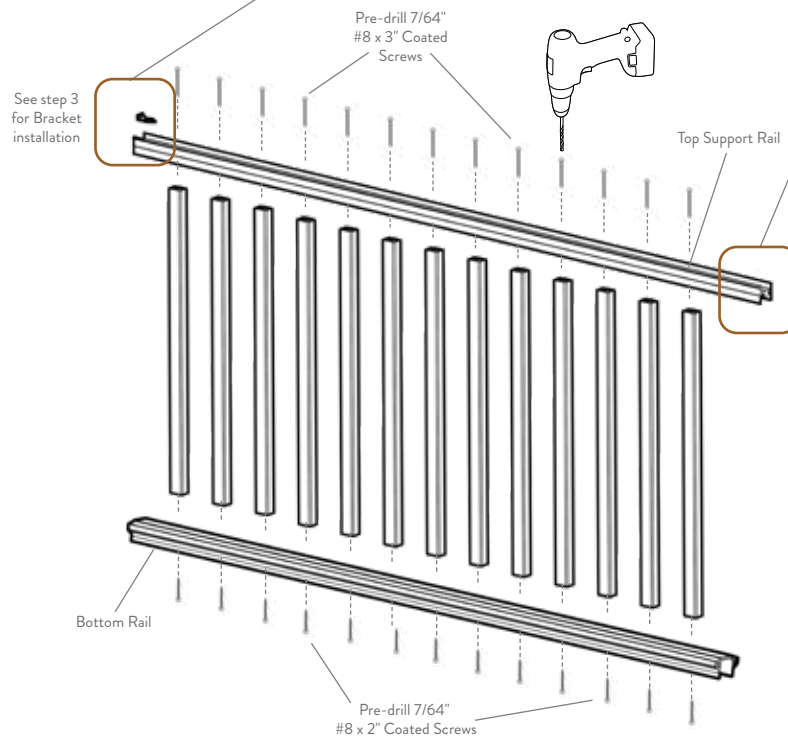
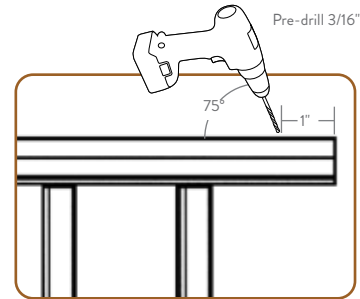
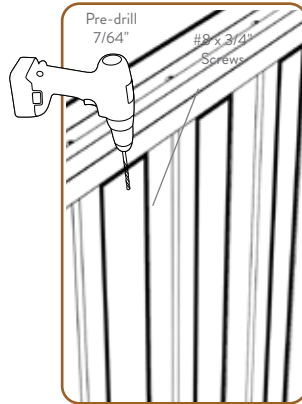



# INSTALLING RESERVE RAIL OVER-THE-POST

## RESERVE RAIL SERIES RAILING

7



### INSTALL RAIL ASSEMBLY

- Align Top Support Rail to center of Posts.
- Use the 3" Green Screws, provided in the Universal Hardware Kit to fasten the Top Support Rail to the 4"x4" post.
- The top of the 4"x4" post, 4" Post Sleeve, and the bottom of the Support Rail should line up to the same height. Test fit railing prior to making final cuts on 4"x4" post and 4" Post Sleeve to ensure these heights are aligned.

7/64" Pre-drill  
#8 x 3"  
Coated Green  
Screws

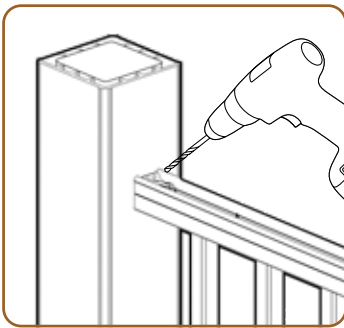

Align to center of post

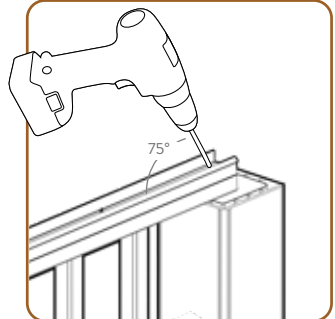
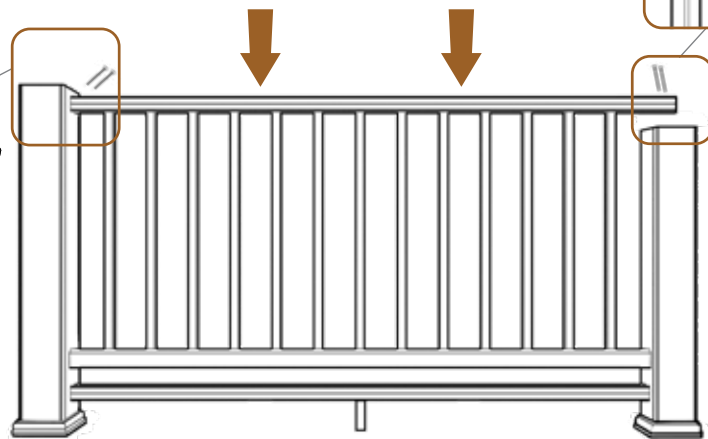

8

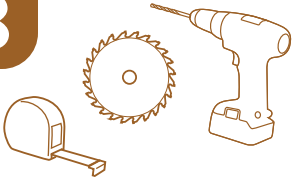

**INSTALL TOP RAIL AND POST CAP**

- Measure and cut the Top Rail to length. Trim both ends for a clean cut.
- Attach Post Cap using exterior grade caulk applied to the underside of the Cap.

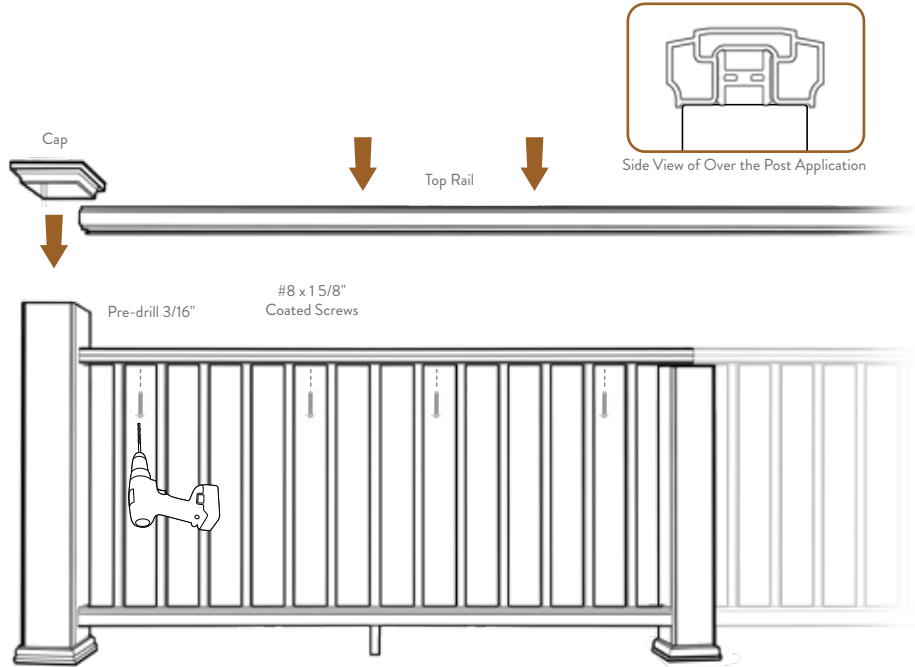
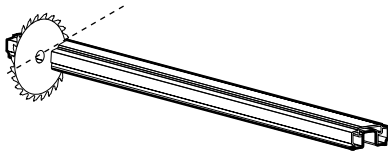

Caution: Screws must be 1 5/8" so they won't go through the Top Rail on straight rail sections.



