



DIVISION: 05 00 00—METALS
Section: 05 52 00—Metal Railings

REPORT HOLDER:

**CPG BUILDING PRODUCTS LLC dba AZEK
 BUILDING PRODUCTS LLC**

EVALUATION SUBJECT:

**ALUMINUM RAILING SYSTEM SERIES CLASSIC
 (1800) AND MODERN (L800); ADA HANDRAILS; AND
 STANCHIONS**

1.0 EVALUATION SCOPE

Compliance with the following codes:

- 2018, 2015, 2012, 2009, and 2006 International Building Code® (IBC)
- 2018, 2015, 2012, 2009, and 2006 *International Residential Code*® (IRC)

Property evaluated:

Structural

2.0 USES

The Aluminum Railing System Series Classic (1800) and Modern (L800); ADA Handrails; and Stanchions described in this report is limited to exterior or interior use as a guardrail system for balconies, porches, and decks of residential and non-residential buildings constructed in accordance with the IBC and IRC.

3.0 DESCRIPTION

3.1 Railing Systems:

3.1.1 Aluminum Railing Systems:

The Aluminum Railing System Series Classic (1800) and Modern (L800) are guards consisting of extruded aluminum posts, sub-rail panel with top and bottom channel rails and balusters, bottom-rail support leg, and top and bottom rail covers. The Aluminum Railing System components are produced from 6063-T5 aluminum alloy; the posts are produced from 6005A-T5 aluminum alloy; and the post base plates are produced from A369 aluminum alloy. The Aluminum Railing System is available in two different series: Classic (1800) and Modern (L800).

The minimum yield and tensile strengths, minimum thickness of the railing components, and manufacturing extrusion process are specified in accordance with the

approved quality control documentation. The railing components are available in a white, black, bronze, or custom powder-coated finish.

3.1.2: ADA Handrails:

The ADA Handrails consist of extruded aluminum round hollow pipe with cast-in-place aluminum wall returns and mid supports.

The round hollow pipes of ADA handrails are made from extruded 6063-T5 aluminum alloy and the 90° wall returns and mid supports are produced from A369 aluminum alloy.

The minimum yield and tensile strengths, minimum thickness of the railing components, and manufacturing extrusion process are specified in the approved quality control documentation. The railing components are available in a white, black, bronze, or custom powder coated finish.

3.1.3 Aluminum Railing System with Stanchions

The Aluminum Railing System can be supported to the substrate with stanchions inserted into 2-inch (50.8 mm) square aluminum posts in lieu of post base plates and consists of guard components as described in Section 3.1.1. The stanchions are produced from extruded 6005A-T5 aluminum alloy.

The minimum yield and tensile strengths, minimum thickness of the railing components, and manufacturing extrusion process are specified in the approved quality control documentation. The railing components are available in a white, black, bronze, or custom powder coated finish.

3.2 Guard:

The height of the railing assembly is 42 inches (1067 mm) above the walking surface. The top rail cover has a wall thickness of 0.055-inch (1.40 mm); and depending on the top rail series, the overall top rail width ranges from 2¼-inches (57.2 mm) minimum to 2½-inches (63.5 mm) maximum, and the overall top rail depth ranges from 1.83-inches (46.5 mm) minimum to 2¼ -inches (57.2 mm) maximum. The bottom rail cover has a wall thickness of 0.055-inch (1.40 mm), a width of 1½-inches (38.1 mm), and a depth of 1½-inches (38.1 mm). For the sub-rail panels, both top and bottom h-channel rails having a varying wall thicknesses between 0.065-inch (1.65 mm) and 0.083-inch (2.11 mm) thick, a width of 1.38-inches (35.1 mm), and a depth of 0.97-inch (24.6 mm). Both top and bottom rail covers and sub-rail panels are available in 6-foot (1.83 m) and 8-foot (2.44 m) lengths. They are produced from

6063-T5 aluminum alloy and come in a powder coated finish. The maximum railing span for each Aluminum Railing System series is noted in Table 1.

The pickets are hollow rectangular extruded 6063-T5 aluminum. The pickets have a wall thickness of 0.050-inch (1.27 mm), a width of ½-inch (12.7 mm), and a depth of ¾-inch (19.1 mm) and come in a powder coated finish. Each picket is inserted in the pre-punched holes on the top and bottom h-channel rails of each sub-rail panel, with a center-to-center spacing of 4 ½-inches (114.3 mm).

The posts come in either 2-inches (50.8 mm) square hollow extruded 6005A-T5 aluminum with a wall thickness of 0.090-inch (2.28 mm) or 3-inches (76.2 mm) square hollow extruded 6005A-T5 aluminum with a wall thickness of 0.065-inch (1.65 mm); and both come in a powder coated finish. The optional post sleeve comes in 4-inches (101.6 mm) square hollow extruded 6063-T5 aluminum with a wall thickness of 0.080-inch (2.03 mm) and come in a powder coated finish. The post base plate is produced from A369 aluminum alloy and is installed at the bottom of the extruded post; it comes in either a 4.02-inches (102.1 mm) by 4.02 inches (102.1) square for the 2-inches (50.8 mm) square post or 4.99-inches (126.7 mm) by 4.99-inches (126.7 mm) square for the 3-inches (76.2 mm) square post. Each post base comes in a powder coated finish. The 6-foot (1.83 m) and 8-foot (2.44 m) railing systems utilize one intermediate bottom rail support leg located at the midspan. Each support leg is a 1½-inches (38.1 mm) square hollow extruded 6063-T5 aluminum with a wall thickness of 0.052-inch (1.32 mm) and comes in a powder coated finish.

The top and bottom rail connector clips are made from 0.080-inch (2.03 mm) thick 5052-H32 aluminum sheets and measures 1-inch (25.4 mm) wide by 0.94-inch (23.9 mm) long by 0.060-inch (1.52 mm) deep, with two 0.16-inch (4.06 mm) diameter holes for securing into the post.

See Figure 1 for details of the components for the aluminum railing system.

The fascia bracket is made from 0.25-inch (6.4 mm) thick 5032-H32 aluminum sheets and measures 3.29-inches (83.5 mm) wide by 5.64-inches (143 mm) long by 6-inches (152.4 mm) in length. The sides have four 0.271-inch (6.9 mm) diameter holes for securing the post to the bracket. The lips have four 0.321-inch (8.2 mm) diameter holes for securing into the supporting substrate. See Figure 4 for component details.

3.3. ADA Handrails:

The ADA Handrails consist of 1½-inch (38.1 mm) outside diameter round hollow pipe and are produced from extruded 6063-T5 aluminum with a nominal wall thickness of 0.230-inch (5.8 mm). The handrail components, 90° wall returns and mid supports and spacers, are produced from A369 aluminum alloy. Each handrail component comes in a powder coated finish. See Table 1 for maximum spans.

See Figure 2 for details of the components for the ADA Handrails.

3.4 Aluminum Railing System with Stanchions

The Aluminum Railing System can be supported to the substrate with stanchions into 2-inch (50.8 mm) square aluminum posts in lieu of post base plates and consists of guard components as described in Section 3.2. The

stanchions consist of extruded 1.715-inch wide by 1.715-inch long (43.6 mm by 43.6 mm) pieces and comes in 20-inch long (508 mm) lengths and are produced from 6005A-T5 aluminum alloy. See Table 1 for maximum spans.

See Figure 3 for details of guards with stanchions.

4.0 DESIGN AND INSTALLATION

4.1 Design:

The Aluminum Railing System Series Classic (I800) and Modern (L800); and Stanchions are satisfactory to resist loads specified in Section 1607.8.1 for the 2018, 2015 and 2012 IBC (Section 1607.7.1 for the 2009 and 2006 IBC) and IRC Table R301.5, when installed at the maximum clear distance between the posts as noted in Table 1. When the railing is supported on one or both ends by the supporting structure, the maximum clear distance between the post and the supporting structure or between the supporting structures must comply with the spans noted in Table 1.

The ADA Handrails are satisfactory to resist loads specified in Section 1607.8.1 for the 2018, 2015 and 2012 IBC (Section 1607.7.1 for the 2009 and 2006 IBC) and IRC Table R301.5. The maximum clear distance between the supports is 72 inches (1828 mm); see Table 1 for maximum spans.

4.2 Installation:

Installation must be in accordance with the manufacturer's published installation instructions, this report, and guard height and opening limitations provisions specified in Sections 1014 and 1015 of the 2018 and 2015 IBC (Sections 1012 and 1013 of the 2012, 2009 and 2006 IBC) and Sections R311 and R312 of the IRC, as applicable. The manufacturer's published installation instructions must be available at the jobsite at all times during installation.

Between the posts: The sub-rail panel consisting of two h-channels and infill pickets is attached to an extrusion post on each end by installing top and bottom rail connector clips with #8 x ¾-inch (19.05 mm) long stainless steel TEK screws. Four screws (two inside and one on each side) per each top and bottom connector clip, as shown in Figure 1. The bottom rail connector clip must be located 3¾-inches (95.25 mm) from the top edge of the clip to the bottom of the post base at center. All connector clips must be installed with two #8 x ¾-inch (19.05 mm) long stainless steel TEK screws. Each top and bottom rail cover snaps over the sub-rail panel's corresponding top and bottom h-channel. Each support leg is fastened at the midspan of the bottom rail with one #8 x ¾-inch-long (19.05 mm) stainless steel TEK screw.

Continuous top rail: A crossover bracket is secured to the top of each 2" post with two #8 x 1.5 inch (38.1 mm) stainless steel TEK screws. The sub-rail panel consisting of two h-channels and infill pickets is attached to the crossover bracket using two #8 x ¾-inch (19.05 mm) TEK stainless steel screws. Bottom of subrail panel is attached with rail connector clips at the bottom as described in between post installations above. Each bottom rail cover snaps over the sub-rail h-channel. Each length of top rail snaps over post and top h-channel. See Figure 1.

Each extruded post is attached to a post base plate with four M8 x 80 mm long stainless steel lag screws, which are fastened on the underside of the post base plate, as shown in Figure 1. The post base plate must be fastened

to the supporting wood substrate with a minimum specific gravity of 0.50 using either four – $\frac{3}{8}$ -inch x 6-inch long (9.5 mm x 152.4 mm) GRK RSS wood screws or four – $\frac{5}{16}$ -inch x 6-inch long (7.9 mm x 152.4 mm) GRK RSS wood screws. When the supporting substrate is concrete having a minimum compressive strength of 3,700 psi (25.5 MPa), each post base plate must be fastened to the supporting concrete substrate using four $\frac{1}{4}$ -inch x 3-inch long (6.35 mm by 76.2 mm) corrosion resistant coated concrete anchor bolts.

When the optional 4-inches (101.6 mm) square post sleeve is installed over an existing nominal 4-by-4 (101.6 mm x 101.6 mm) wood post, all wood post fastener connections to the supporting substrate and sub-rail connections through the post sleeve to the wood post must be designed by a registered design professional.

ADA Handrails must have each support attached to the supporting wood substrate with a minimum specific gravity of 0.49. Each 90° Wall Return and mid support is fastened to the wood substrate using three – $\frac{5}{16}$ -inch x 4 inch-long (7.9 mm by 101.6 mm) construction lag screws. When each 90° Wall Return and mid support is fastened to 3-inches (76.2 mm) square hollow extruded 6005A-T5 aluminum with a wall thickness of 0.065-inch (1.65 mm), each connection must use three – #10 x $1\frac{1}{2}$ -inch long (38.1 mm) stainless steel TEK screws.

When stanchions are used to support 2-inch (50.8 mm) square aluminum posts in lieu of post base plates, the 2-inch (50.8 mm) square post must fit over each stanchion at a minimum length of 14.75 inches (374.6 mm). The connections of the stanchion to the stanchion mount and the mount to the supporting structure must be designed by a registered design professional.

When fascia bracket assembly is used in lieu of post base for 3-inch (76.2 mm) square posts installed over the supporting concrete substrate having a minimum compressive strength of 3,900 psi (26.9 MPa), the posts with fascia bracket assembly must be fastened to the supporting concrete substrate using four $\frac{1}{4}$ -inch x 3-inch long (6.35 mm by 76.2 mm) corrosion resistant coated concrete anchor bolts. See Table 1 for spans and Figure 4 for component details.

5.0 CONDITIONS OF USE

The Aluminum Railing System Series Classic (I800) and Modern (L800); ADA Handrails; and Stanchions described in this report complies with, or is a suitable alternative to what is specified in, those codes listed in Section 1.0 of this report, subject to the following conditions:

- 5.1 This product is limited to exterior or interior use as a guardrail system for balconies, porches, and decks of residential and non-residential buildings constructed in accordance with the IBC and IRC.
- 5.2 Installation must comply with this report, the manufacturer's published installation instructions and the applicable code. When the manufacturer's published installation instructions differ from this report, this report governs.
- 5.3 Only those fasteners and fastener configurations described in this report have been evaluated for the installation of the Aluminum Railing System Series

Classic (I800) and Modern (L800); and ADA handrails. The compatibility of the post base plate's fasteners with the supporting construction, including chemically treated wood, is outside the scope of this report.

- 5.4 The Aluminum Railing System Series Classic (I800) and Modern (L800); and ADA Handrails must be directly fastened to supporting construction having adequate strength and stiffness. Where required by the code official, engineering calculations and construction documents consistent with this report must be submitted for approval. The calculations must verify that the supporting construction complies with the applicable building code requirements and is adequate to resist the loads imparted upon it from the products and systems discussed in this report. The documents must contain details of the attachment to the supporting structure consistent with the requirements of this report. The documents must be prepared by a registered design professional where required by the statutes of the jurisdiction in which the project is to be constructed.
- 5.5 The top rail of the Aluminum Railing System, for use as a handrail, is outside the scope of this report.
- 5.6 The connections of the stanchion to the stanchion mount and the stanchion mount to the supporting structure must be designed by a registered design professional and is outside the scope of this report.
- 5.7 The products are manufactured under a quality control program with inspections by ICC-ES.

6.0 EVIDENCE SUBMITTED

Data in accordance with the ICC-ES Acceptance Criteria for Handrails and Guards (AC273), dated June 2017 (editorially revised January 2019).

7.0 IDENTIFICATION

- 7.1 The Aluminum Railing System Series Classic (I800) and Modern (L800); ADA handrails; and Stanchions described in this report is identified by a stamp, on each individual piece or on the packaging, bearing the report holder's name (Azek Building Products LLC), the product name (The Aluminum Railing System Series Classic (I800) or Modern (L800); ADA handrails; and Stanchions), the allowable span, and the ICC-ES evaluation report number (ESR-4217).
- 7.2 The report holder's contact information is the following:

**CPG BUILDING PRODUCTS LLC dba AZEK
BUILDING PRODUCTS LLC
894 PRAIRIE AVENUE
WILMINGTON, OHIO 45177
www.AZEKCO.com**

TABLE 1 - MAXIMUM GUARDRAIL SYSTEM SPANS¹

PRODUCT	POST HEIGHT (INCH)	MAXIMUM SPAN - IBC (INCH)	MAXIMUM SPAN - IRC (INCH)
ALUMINUM RAILING SYSTEM WITH 3-INCH ALUMINUM POSTS ATTACHED TO WOOD SUBSTRATE ²	42.000	68.300	91.313
ALUMINUM RAILING SYSTEM WITH 3-INCH ALUMINUM POSTS ATTACHED TO CONCRETE SUBSTRATE ³	42.000	69.430	91.313
ALUMINUM RAILING SYSTEM WITH 2-INCH ALUMINUM POSTS ATTACHED TO CONCRETE SUBSTRATE ³	42.000	66.000	91.313
ALUMINUM RAILING SYSTEM WITH 2-INCH ALUMINUM POSTS WITH STANCHIONS MOUNTED TO CONCRETE SUBSTRATE ⁴	42.000	66.000	91.313
ALUMINUM RAILING SYSTEM WITH ALUMINUM 3" POSTS AND FASCIA BRACKET ASSEMBLY ATTACHED TO CONCRETE SUBSTRATE ⁷	42.000	55.960	91.313
ADA HANDRAILS WITH 90° BRACKET ASSEMBLY ATTACHED TO WOOD SUBSTRATE ⁵	N/A	72.000	72.000
ADA HANDRAILS WITH 90° BRACKET ASSEMBLY ATTACHED TO 3-INCH ALUMINUM POST WITH BACKER PLATE ⁶	N/A	72.000	72.000
ADA HANDRAILS WITH MIDSPAN BRACKET ASSEMBLY ATTACHED TO WOOD SUBSTRATE ⁵	N/A	72.000	72.000
ADA HANDRAILS WITH MIDSPAN BRACKET ASSEMBLY ATTACHED TO 2-INCH ALUMINUM POST ⁶	N/A	72.000	72.000

For SI: 1 inch = 25.4 mm

¹Spans are from inside face to inside face of post.

²Wood substrate must have a minimum specific gravity of 0.50 where each connection must use either four - $\frac{3}{8}$ -inch x 6-inch long GRK RSS wood screws for IBC application or four - $\frac{5}{16}$ -inch x 6 inch-long GRK RSS wood screws for IRC application.

³Concrete substrate must have a minimum compressive strength of 3,700 psi where each connection must use four - 1/4-inch x 3-inch long concrete anchor bolts supplied by Azek Building Products LLC.

⁴Connections of stanchion to stanchion mount and stanchion mount to the substrate must be designed by a registered design professional.

⁵Wood substrate must have a minimum specific gravity of 0.49 where each connection must use three - $\frac{5}{16}$ -inch x 4-inch long construction lag screws.

⁶Each connection to aluminum post must use three - No. 10 x 1 $\frac{1}{2}$ -inch long stainless steel TEK screws.

⁷Concrete substrate must have a minimum compressive strength of 3,900 psi where each connection must use four - $\frac{1}{4}$ -inch x 3-inch long concrete anchor bolts supplied by Ultralox.

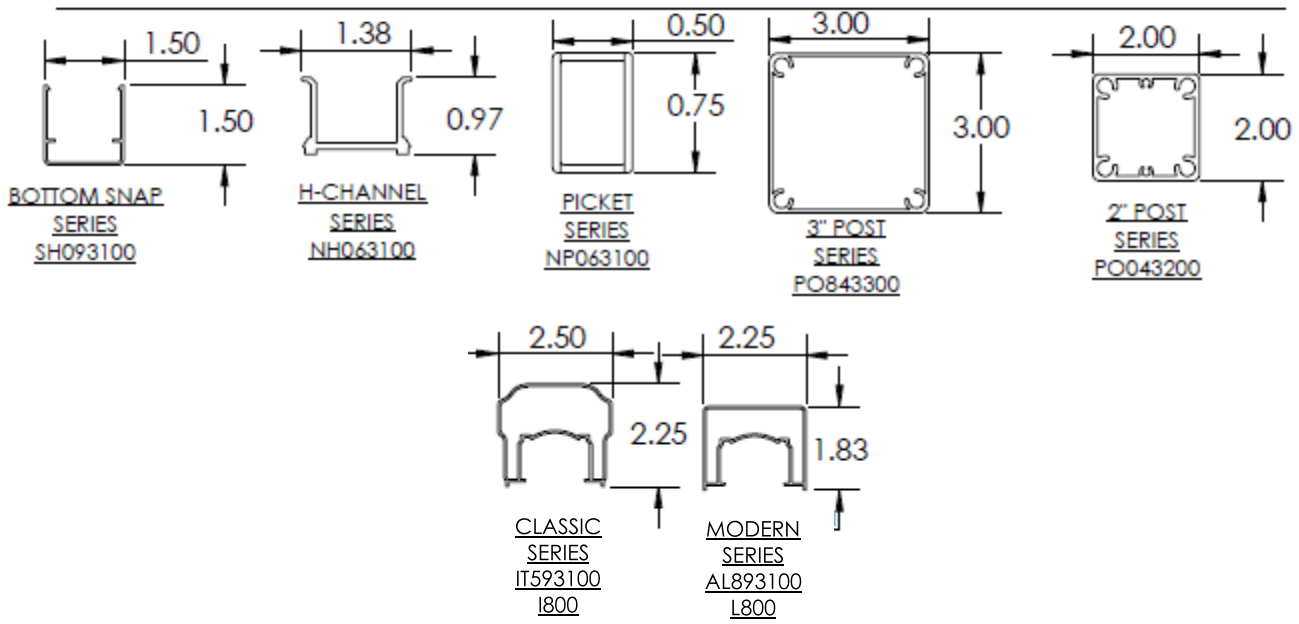
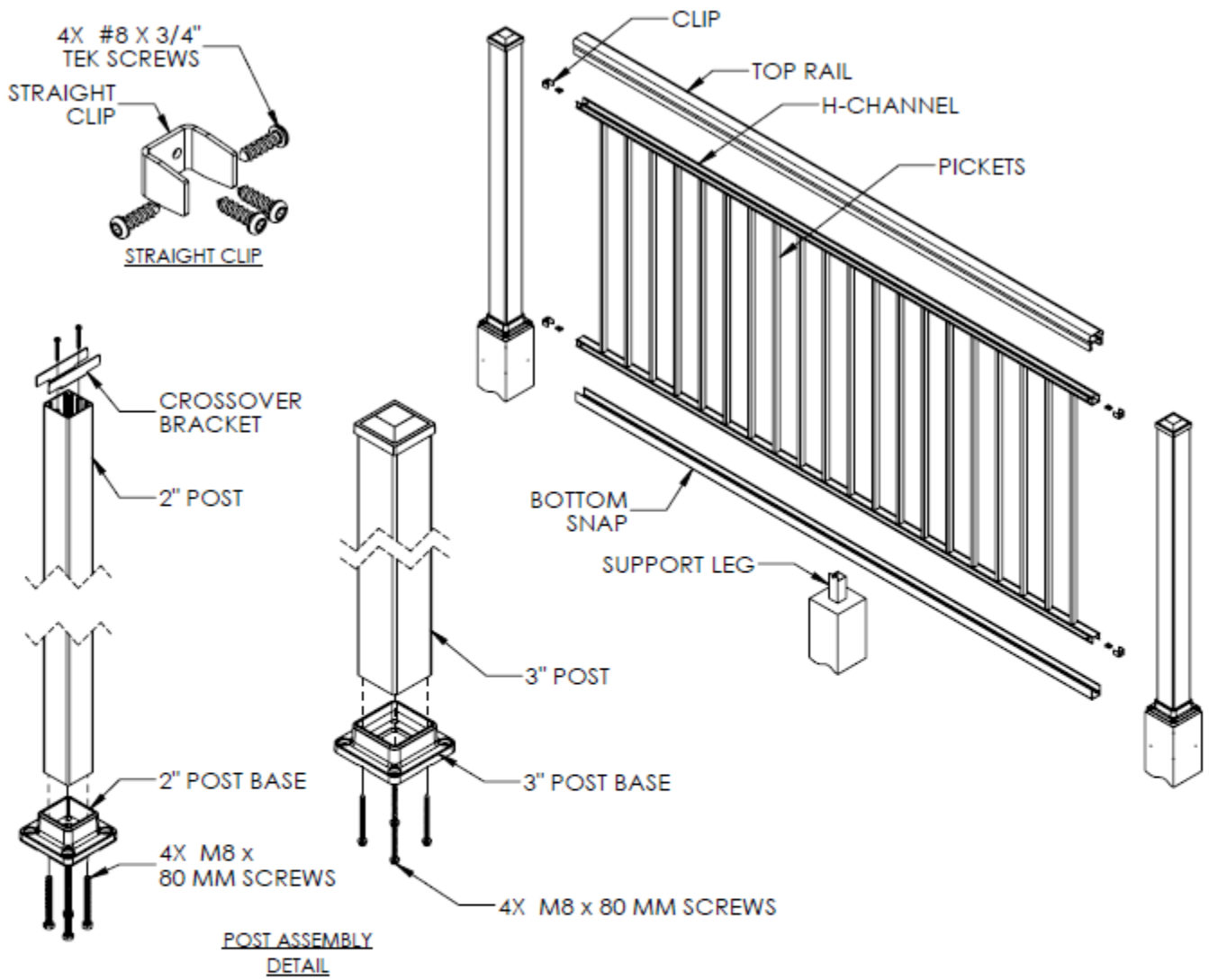

FIGURE 1—TYPICAL GUARDRAIL ASSEMBLY AND COMPONENT PROFILES

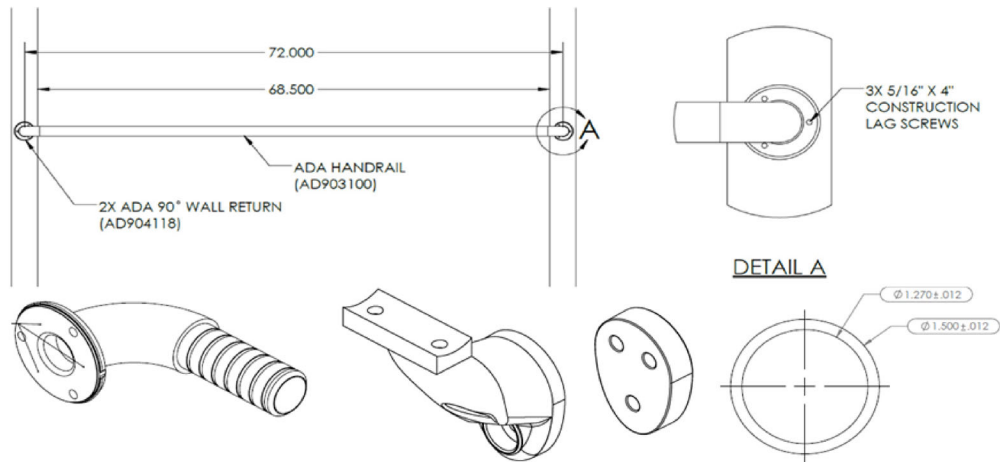

FIGURE 2—TYPICAL ADA HANDRAIL - COMPONENTS

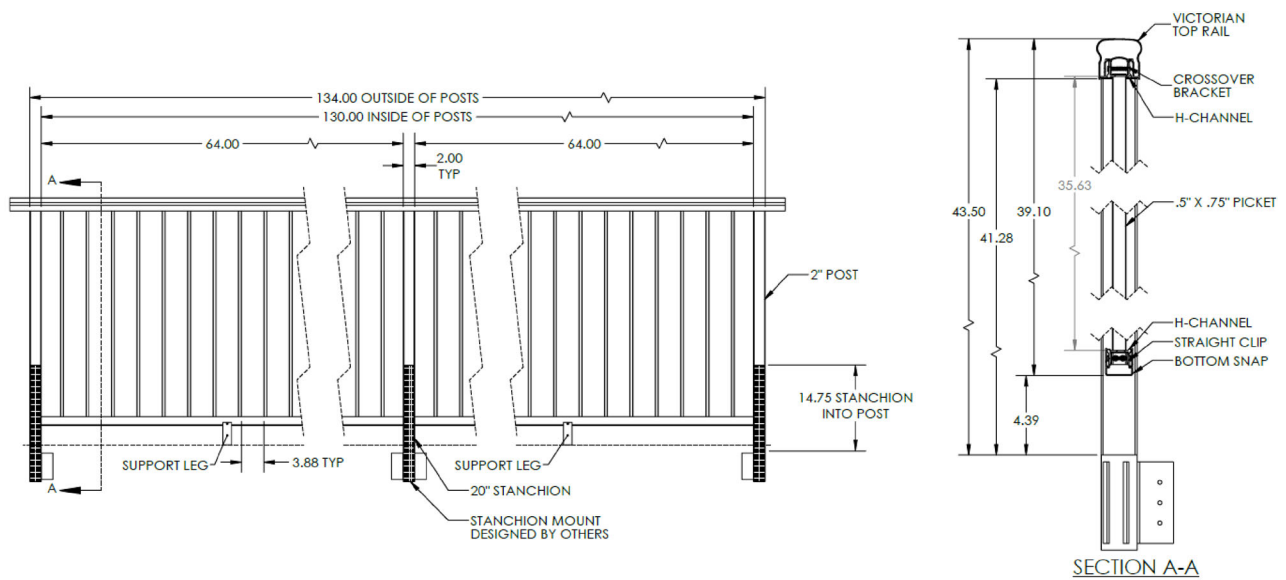

FIGURE 3 —TYPICAL GUARD SYSTEM WITH STANCHIONS

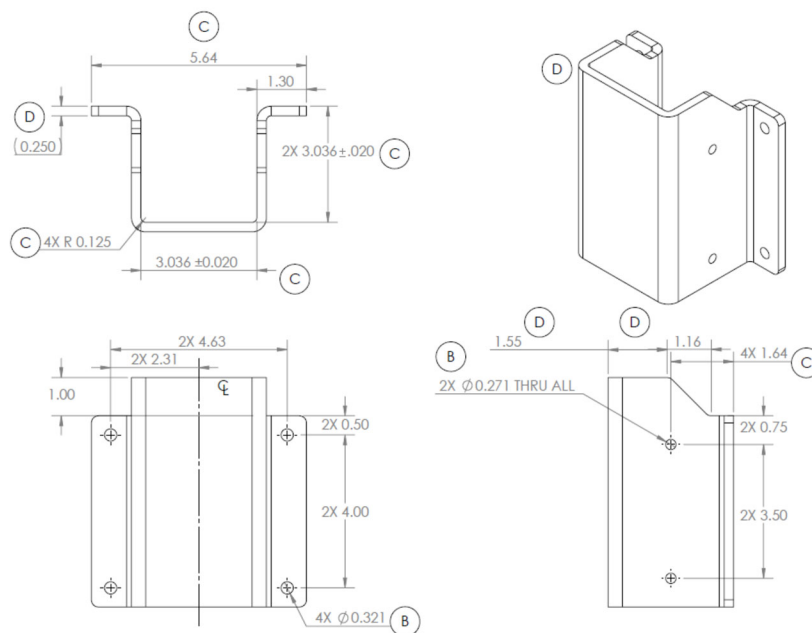

FIGURE 4 – FASCIA BRACKET ASSEMBLY FOR 3" POST