

STATEMENT™ RAIL



INSTALL GUIDE



IMPORTANT NOTES

- Please read all instructions completely before starting any part of the installation. Always make sure to visit www.TimberTech.com to ensure you are viewing the most current installation instructions, care and cleaning, technical information and more.
- TimberTech Railing should be installed using the same good building principles used to install wood or composite railing and in accordance with the local building codes and the installation guidelines included below.
- AZEK Co. LLC accepts no liability or responsibility for the improper installation of this product.
- TimberTech Railing may not be suitable for every application and it is the sole responsibility of the installer to be sure that TimberTech Railing is fit for the intended use. Since all installations are unique, it is also the installer's responsibility to determine specific requirements in regards to each Rail application.
- AZEK Co. LLC recommends that all applications be reviewed by a licensed architect, engineer or local building official before installation. If you have any questions or need further assistance, please call AZEK Customer Service at 877-ASK-AZEK (877-275-2935) or visit our website at www.TimberTech.com.
- TimberTech Railing is tested as a whole system and should be used that way. It is not intended to be used in conjunction with other railing systems or fasteners.
- The following Installation Guidelines are applicable for installation of TimberTech Statement Rail and Pinnacle Rail.
- **IMPORTANT:** DRIVETOOL/DRILL is not configured or set to the "SCREW" setting and the clutch feature is engaged when driving and/or tightening the Rail Bracket Screws as this may strip/break the stainless steel fastener head. Do NOT use an impact driver for the installation of the #8 x 1-1/4" Rail Bracket Screws in Statement Rail and Pinnacle Rail systems.
- **SAFETY:** Always wear goggles when handling, cutting, drilling and fastening materials.
- Failure to install this product in accordance with applicable building codes and TimberTech's written Railing Install Guide may lead to personal injury, affect rail system performance and void the product warranty.
- The buildup or generation of static electricity is a naturally occurring phenomenon in many plastic based products such as carpeting, upholstery, and clothing, and can occur on alternative decking under certain environmental conditions. This static electricity can discharge once contact is made with hardware, railing, or other conductors of electricity.



Find install videos, written instructions and a chat link at timbertech.com/resources/installation-help/.

NOTE: IF INSTALLING POST LIGHTING, WIRING MUST BE INSTALLED PRIOR TO SECURING POSTS TO DECK/STAIR SURFACE AND INSTALLING TOP RAILS.

It is the responsibility of the installer to meet all local, code requirements and obtain all required building permits. The installer should determine and implement appropriate installation techniques for each installation situation. The AZEK Company or its reseller shall not be held responsible for improper or unsafe installations.

DARK PAINT CAUTION

If you choose to paint your TimberTech PVC Statement Rail and/or Pinnacle Rail Product, TimberTech recommends the use of Exterior 100% Acrylic Latex paint. Preferably paints designed for use with PVC products. Please contact your local paint dealer for professional assistance. Due to the inherent expansion and contraction characteristics of PVC, TimberTech PVC Statement and Pinnacle Railing should only be painted colors with an LRV (light reflective value) greater than 55. Do not use darker colors due to excessive expansion/contraction, movement, warping, oil canning, distortion and will void the product warranty.







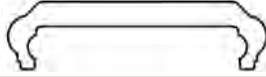
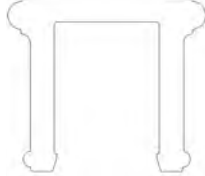

COLOR RANGE	KEY COLORS SELECTION CRITERIA	PAINT TYPE
Lighter paint colors only	Must have a light reflective value (LRV) of above 55	Exterior 100% Acrylic Latex

CLEANING PRODUCTS FOR TIMBERTECH PVC RAILING PRODUCTS

Cleaning TimberTech PVC Statement Rail and Pinnacle Rail is easy and fast with most major household cleaners. The cleaning solution should be applied and then rinsed off completely and wiped dry. As with any cleaning material, the cleaning solution should not be left to stand on the components for an extended period of time and should be trialed on a sample piece prior to any application. Always work in a manageable area to not allow the cleaner to dry onto the railing.

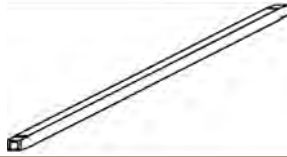
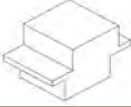
WHAT TO AVOID

Harsh cleaners with glycol ethers or ethanol type solvents and/or isopropyl alcohol are not recommended. Examples of these harmful cleaners are Goof Off®, Walmart "Great Value All Purpose Cleaner®" (glycol ether), 409 General Purpose® (2- Butoxyethanol) and Greased Lightning® (glycol ether), citrus cleaners, abrasive cleaners, and solvents such as acetone, paint remover, lacquer thinner, composite deck cleaners and sodium hydro chloride based cleaners.

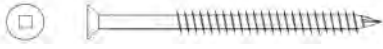
ITEM		QUANTITY PER KIT	
		6'	8'
Rail Caps 2-3/4" Graspable		1	1
Common Rail Used at Top & Bottom of Balusters		2	2
Upper & Lower Aluminum Reinforcement		2	2
Level Rail Brackets Included in Level Rail Kits		4	4
Baluster 1-1/4" Square 3/4" Diameter Aluminum Baluster		14 16	18 22
Stair Rail Brackets Included with Stair Rail Kits Only		4	4
Baluster 1-1/4" Square 32" Length Machined for Stair Rail Kits Only		14	18
Stair Rail Offset Spacer Included with Stair Rail Kits Only		2	2
Crush Block 1-1/4" Square X 4"		1	2
(A) Rail Bracket Screws #8 X 1-1/4" Flat Head Square Drive		16	16
(B) Rail Attachment Screws #10 X 3" Slot Hex Washer Head		10	10
(C) Crush Block Screws #8 X 2-1/2" Flat Head Square Drive		6	6

LEVEL RAIL SECTION APPLICATION

1 MEASURE TO DETERMINE BALUSTER LAYOUT, CUT RAIL SECTIONS TO LENGTH

- a. Ensure newels or columns to which rail will be mounted are plumb and sturdy enough to support rail. If newel/column covers are used, ensure they have blocking at each location where railing will be attached.
- b. Measure span at top and bottom rail locations.
- c. Standard baluster spacing (with the variable spaces at the ends of each rail section), is the only method of spacing available with the Statement Series Rail. Hold one section of the Top/Bottom Common Rail at the bottom of the newels, and using the baluster locations as a reference, determine the best end baluster spacing by either locating a baluster directly at the center of the rail section, or the mid-point between two balusters as the center of the rail section. Once the best end baluster spacing is decided, mark both ends of the rail at the newels and square cut using a miter box. The Top and Bottom Common Rail must be cut with exactly the same spacing, to ensure that the balusters will be plumb. Cut the Rail Top Cap to the required length.

2 PREPARE ALUMINUM REINFORCEMENTS

- a. Cut the aluminum rail reinforcements to length, 1/4" shorter than the PVC rails.
- b. Attach a mounting bracket to both ends of each Aluminum Rail Reinforcement, using three rail *bracket screws* (A). Lubricate the threads with soap or oil to avoid binding and use a clutch type drill to avoid stripping screws. Note that the reinforcement for the bottom rail will be installed with the deeper hollow portion facing up, and the reinforcement for the top rail with the deeper hollow portion facing down.
- c. Locate crush block(s) provided to the bottom Aluminum Rail Reinforcement, with spacing no greater than 36" from the end, or between Crush Blocks. **NOTE:** In an Aluminum Baluster application, do not install Crush block at this step. See 4a below.
- d. Drill a 3/16" hole through the bottom Aluminum Rail Reinforcement, and secure each crush block using one *crush block screw* (C).
- e. Drill one additional 3/16" hole at each end of the bottom Aluminum Rail Reinforcement for drainage.

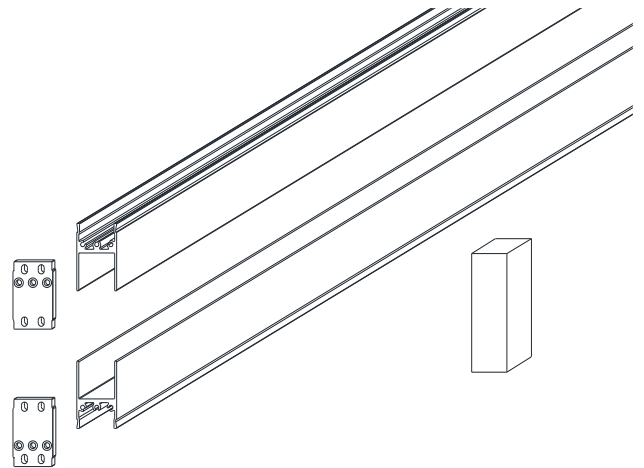

3 INSTALL RAIL SECTION USING 1-1/4" HOLLOW SQUARE BALUSTERS

- a. Position the bottom Aluminum Rail Reinforcement, with crush block(s) attached, between the newels or columns, centered on newel or column face. Level and secure each end with two *rail attachment screws* (B).
- b. Place one of the sections of the Top/Bottom Common Rail over the bottom Aluminum Rail Reinforcement.
- c. Place balusters into all the baluster slots.
- d. Starting at one end, align and place the other section of the Top/Bottom Common Rail over top of the balusters. Note that the hollow portion of the Top/Bottom Common Rail will be facing up.
- e. Drill three 3/16" holes, one 3" from each end and one at the center of the top Aluminum Rail Reinforcement for drainage.
- f. Position the top Aluminum Rail Reinforcement, deeper hollow side facing down, over the ends of the balusters.
- g. Ensure that the Aluminum Rail Reinforcement is fully seated on top of all the balusters, and centered on newel or column faces. Pull the Common Rail up against the Aluminum Rail Reinforcement, being careful not to un-seat the Aluminum Reinforcement from the tops of the Balusters, and secure each end with two *rail attachment screws* (B).
- h. Apply a bead of latex caulk at the contact areas where the Rail Top Cap seats on the Top Common Rail. Place the Rail Top Cap on the Common Rail and press firmly down along the length to lock it in place.

4

INSTALL RAIL SECTION USING 3/4" ROUND ALUMINUM BALUSTERS

- a. Cut the PVC Baluster track to length, and place it into the bottom Aluminum Rail Reinforcement, grooved side up. Locate crush block(s) provided, with spacing no greater than 36" from the end, or between Crush Blocks. Drill a 3/16" hole through the baluster track and the bottom Aluminum Rail Reinforcement, and secure each crush block using one *crush block screw* (C).
- b. Position the bottom Aluminum Rail Reinforcement, with crush block(s) attached, between the newels or columns, centered on newel or column face. Level and secure each end with two *rail attachment screws* (B).
- c. Place one of the sections of the Top/Bottom Common Rail over the bottom Aluminum Rail Reinforcement.
- d. Place Balusters into all the holes. **NOTE:** Ensure that the ends of the balusters are seated in the groove of the PVC Baluster track.
- e. Starting at one end, align and place the other section of the Top/Bottom Common Rail over top of the balusters. Note that the hollow portion of the Top/Bottom Common Rail will be facing up.
- f. Drill three 3/16" holes, one 3" from each end and one at the center of the top Aluminum Rail Reinforcement for drainage.
- g. Cut the other PVC Baluster track to length and place inside the deeper hollow side of the top Aluminum Rail Reinforcement, so that the grooved side will be facing down when placed over the ends of the balusters.
- h. Position the top Aluminum Rail Reinforcement, with PVC Baluster track in place, over the ends of the balusters.
- i. Ensure that the upper and lower ends of the balusters are seated in the grooves of the baluster tracks, and that the Aluminum Rail Reinforcement is fully seated on top of all the balusters, and centered on newel or column faces. Pull the Common Rail up against the Aluminum Rail Reinforcement, being careful not to un-seat the Aluminum Reinforcement from the tops of the Balusters, and secure each end with two *rail attachment screws* (B).
- j. Apply a bead of latex caulk at the contact areas where the Rail Top Cap seats on the Top Common Rail. Place the Rail Top Cap on the Common Rail and press firmly down along the length to lock it in place.



**STAIR OR RAKE RAIL APPLICATION –
1-1/4" SQUARE BALUSTERS**

1 DETERMINE BALUSTER LAYOUT, PREPARE PVC RAILS

- a. Ensure newels or columns to which rail will be mounted are plumb and sturdy enough to support rail. If newel/column covers are used, ensure they have blocking at each location where railing will be attached.
- b. Standard baluster spacing (with the variable spaces at the ends of each rail section), is the only method of spacing available with the Statement Series Rail. Determine best end spacing by placing the bottom Common Rail on the stairs, between the newels and either locating a Baluster directly at the center of the rail section, or the mid-point between two Balusters as the center of the rail section. Once baluster spacing is determined, mark ends of the bottom Common Rail with length and angles.

- c. Using the two Stair Rail Offset Spacers supplied with Stair Rail kit, place the Top and Bottom Common Rail together and make a single cut across each end of the Common Rails, at the locations/angles determined above. Both Common Rails will be the same length, but the Stair Rail Offset Spacers will off-set the baluster spacing by 3/16" to keep the Balusters plumb once installed at the stair angle.
NOTE: Do not cut the Rail Top Cap until section is assembled and secured at all 4 mounting points.

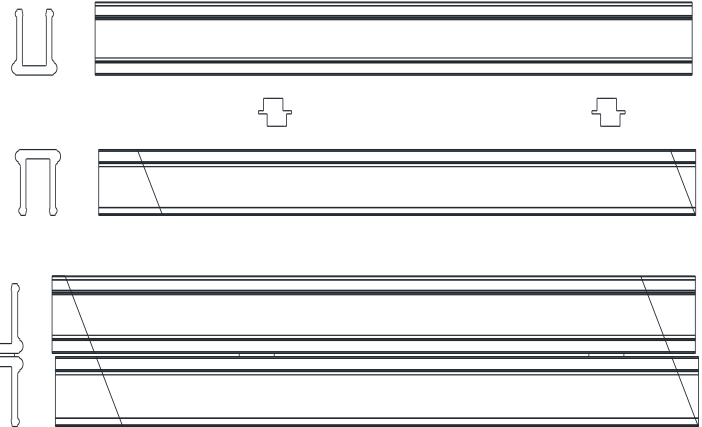

2 PREPARE ALUMINUM REINFORCEMENTS

- a. Cut the Aluminum Rail Reinforcements to the same angles as the Top and Bottom Common Rail, but 3/8" shorter in length. Note that the top reinforcement is oriented with the deeper hollow portion facing down, and the bottom reinforcement is oriented with the deeper hollow portion facing up. Secure a Stair Rail Bracket to each end of both reinforcements, using three *rail bracket screws* (A). Lubricate the threads with soap to avoid binding and use a clutch type drill to avoid stripping screws.
- b. Cut one end of Crush Block to angle of rail and locate to the bottom aluminum rail reinforcement, with spacing no greater than 32" from the end, or between Crush Blocks. Ensure that the Crush Block(s) will be located on a stair tread.
- c. Drill a 3/16" hole through the bottom Aluminum Rail Reinforcement, and secure each crush block using one *crush block screw* (C).
- d. Position bottom Aluminum Rail Reinforcement, with crush block(s) attached, between the newels or columns, centered on newel or column face, and ensure proper placement in relation to the ends of the treads. Secure each end with two *rail attachment screws* (B). **NOTE:** Due to the angles, the heads of the *rail bracket screws* (A) used to attach the brackets to the reinforcements will protrude from the face of the brackets. Use care to avoid damaging the newel posts when positioning the reinforcements.

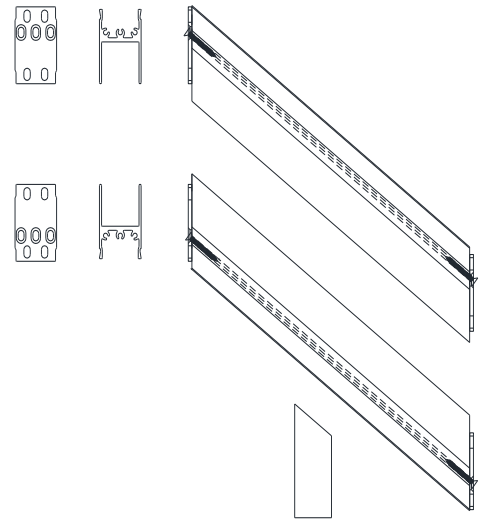

3 ASSEMBLE RAIL/BALUSTER SECTION

- a. Insert balusters into the bottom Common Rail, with the lower notch oriented so that it is on the up-hill side of the baluster when the rail is in place. Each Baluster should 'click' into place.
- b. Starting at one end, align and place the other section of the Top/Bottom Common Rail over top of the balusters. Note that the hollow portion of the Top/Bottom Common Rail will be facing up, and ensure that the rake angles at the ends correspond to those on the bottom Common rail. Ensure all Balusters are properly seated so that the notch is 'clicked' into the Top/Bottom Common Rails. If a baluster pushed through the rail too far, or not far enough, it may cause the machined slot to be deformed. The Assembly should rack easily.

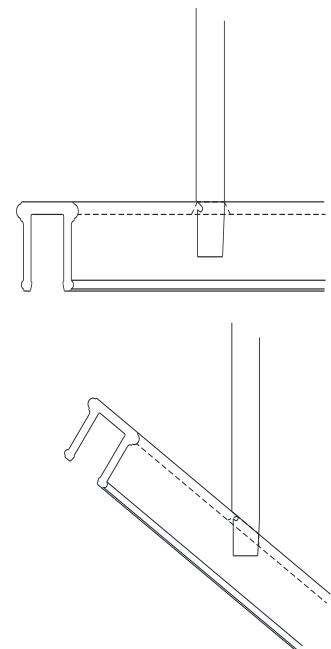

4 INSTALL RAIL

- a. Rack and position the rail/baluster assembly between newels or columns and seat fully down on bottom aluminum rail reinforcement.
- b. Seat upper Aluminum Rail Reinforcement into the top Common Rail.
- c. Ensure rail is centered on face of newel or column and secure each end with two *rail attachment screws* (B).
- d. Measure and cut the Top Cap to required angle and length. Apply a bead of latex caulk at the contact areas where the Rail Top Cap seats on the Top Common Rail and Seat the Rail Cap fully onto the Top Common Rail.

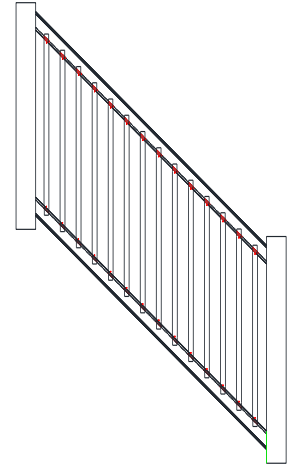

STAIR OR RAKE RAIL APPLICATION – 3/4" ALUMINUM BALUSTERS

1 DETERMINE BALUSTER LAYOUT, PREPARE PVC RAILS

- a. Ensure newels or columns to which rail will be mounted are plumb and sturdy enough to support rail. If newel/column covers are used, ensure they have blocking at each location where railing will be attached.
- b. Standard baluster spacing (with the variable spaces at the ends of each rail section), is the only method of spacing available with the Statement Series Rail. Determine best end spacing by placing the bottom Common Rail on the stairs, between the newels and either locating a Baluster directly at the center of the rail section, or the mid-point between two Balusters as the center of the rail section. Once baluster spacing is determined, mark ends of the bottom Common Rail with length and angles. **NOTE: The routed holes for the aluminum balusters are only angled in one direction. Ensure that the rail is oriented properly for the rake angle and dry fit a set with two balusters before marking and cutting.**
- c. Place the Top and Bottom Common Rail together and pass two balusters through the routed holes to ensure the hole patterns are properly aligned. Make a single cut across each end of the Common Rails, at the locations/angles. **NOTE: Do not cut the Rail Top Cap until section is assembled and secured at all 4 mounting points.**

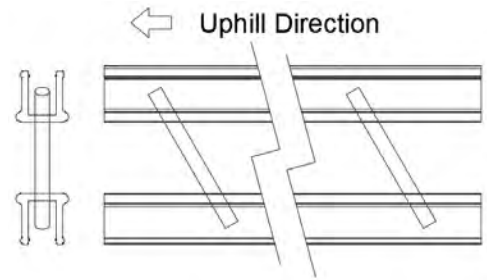

2 PREPARE ALUMINUM REINFORCEMENTS AND BALUSTER TRACKS

- a. Cut the Aluminum Rail Reinforcements and the Baluster Tracks to the same angles as the Top and Bottom Common Rail, but 1/4" shorter in length. Note that the top reinforcement is oriented with the deeper hollow portion facing down, and the bottom reinforcement is oriented with the deeper hollow portion facing up. Baluster Tracks will be inserted in the reinforcement in the orientation shown. Secure a Stair Rail Bracket to each end of both reinforcements, using three *rail bracket screws* (A). Lubricate the threads with soap to avoid binding and use a clutch type drill to avoid stripping screws.
- b. Cut one end of Crush Block to angle of rail and locate to the bottom aluminum rail reinforcement, with spacing no greater than 32" from the end, or between Crush Blocks. Ensure that the Crush Block(s) will be located on a stair tread.
- c. Drill a 3/16" hole through the bottom Aluminum Rail Reinforcement, and secure each crush block using one *crush block screw* (C).
- d. Position bottom Aluminum Rail Reinforcement, with crush block(s) attached and Baluster Track inserted, between the newels or columns, centered on newel or column face, and ensure proper placement in relation to the ends of the treads. Secure each end with two *rail attachment screws* (B). **NOTE: Due to the angles, the heads of the rail bracket screws (A) used to attach the brackets to the reinforcements will protrude from the face of the brackets. Use care to avoid damaging the newel posts when positioning the reinforcements.**

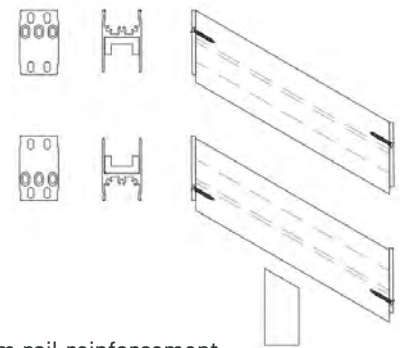

3 INSERT COMMON RAILS AND BALUSTERS AND SECURE

- a. Making sure that the proper common rail section is selected, snap it in place over the bottom reinforcement. Place the top common rail on top of the bottom common rail with the “U” shape facing up and making sure the orientation is correct and the routed holes line up with the bottom common rail.
- b. Insert all balusters through both sets of common rail holes, ensuring that they seat fully in the baluster track and stand upright.
- c. Seat the upper aluminum reinforcement with baluster track inserted over the top of the balusters, ensuring that they all seat fully in the baluster track. Ensure reinforcement is centered on face of newel or column and secure each end with two *rail attachment screws* (B).

4 FINALIZE AND INSTALL RAIL CAP

- a. Slide the top common rail vertically up until it snaps into place around the reinforcement.
- b. Measure and cut the Top Cap to required angle and length. Apply a bead of latex caulk at the contact areas where the Rail Top Cap seats on the Top Common Rail and Seat the Rail Cap fully onto the Top Common Rail.



AZEK Building Products
1330 W Fulton Market, Suite #350
Chicago, IL 60607

©2022 AZEK Building Products. All Rights Reserved.

