

PINNACLE™ RAIL



INSTALL GUIDE



IMPORTANT NOTES

- Please read all instructions completely before starting any part of the installation. Always make sure to visit www.TimberTech.com to ensure you are viewing the most current installation instructions, care and cleaning, technical information and more.
- TimberTech Railing should be installed using the same good building principles used to install wood or composite railing and in accordance with the local building codes and the installation guidelines included below.
- AZEK Co. LLC accepts no liability or responsibility for the improper installation of this product.
- TimberTech Railing may not be suitable for every application and it is the sole responsibility of the installer to be sure that TimberTech Railing is fit for the intended use. Since all installations are unique, it is also the installer's responsibility to determine specific requirements in regards to each Rail application.
- AZEK Co. LLC recommends that all applications be reviewed by a licensed architect, engineer or local building official before installation. If you have any questions or need further assistance, please call AZEK Customer Service at 877-ASK-AZEK (877-275-2935) or visit our website at www.TimberTech.com.
- TimberTech Railing is tested as a whole system and should be used that way. It is not intended to be used in conjunction with other railing systems or fasteners.
- The following Installation Guidelines are applicable for installation of TimberTech Statement Rail and Pinnacle Rail.
- **IMPORTANT:** DRIVETOOL/DRILL is not configured or set to the "SCREW" setting and the clutch feature is engaged when driving and/or tightening the Rail Bracket Screws as this may strip/break the stainless steel fastener head. Do NOT use an impact driver for the installation of the #8 x 1-1/4" Rail Bracket Screws in Statement Rail and Pinnacle Rail systems.
- **SAFETY:** Always wear goggles when handling, cutting, drilling and fastening materials.
- Failure to install this product in accordance with applicable building codes and TimberTech's written Railing Install Guide may lead to personal injury, affect rail system performance and void the product warranty.
- The buildup or generation of static electricity is a naturally occurring phenomenon in many plastic based products such as carpeting, upholstery, and clothing, and can occur on alternative decking under certain environmental conditions. This static electricity can discharge once contact is made with hardware, railing, or other conductors of electricity.



Find install videos, written instructions and a chat link at timbertech.com/resources/installation-help/.

NOTE: IF INSTALLING POST LIGHTING, WIRING MUST BE INSTALLED PRIOR TO SECURING POSTS TO DECK/STAIR SURFACE AND INSTALLING TOP RAILS.

It is the responsibility of the installer to meet all local, code requirements and obtain all required building permits. The installer should determine and implement appropriate installation techniques for each installation situation. The AZEK Company or its reseller shall not be held responsible for improper or unsafe installations.



IMPORTANT INFORMATION ABOUT THE PINNACLE RAIL

The Pinnacle Rail system utilizes pre-marked dimples to assist in locating the balusters for equal spacing. Dimples are used rather than pre-drilled holes to give you the flexibility to use the pre-marked standard locations or to determine your own baluster locations (when using custom spacing check local building code requirements).

Please take note that these pre-marked baluster locations are designed for Post Center to Post Center dimensions of 6' and 8', respectively. If utilizing the pre-marked baluster locations, the maximum rail span will be 4.25" less than the post center dimension. For rail spans that are in excess of that dimension you will need to establish your own baluster locations or move up to the next size rail kit to meet spacing code requirements. The quantity of pre-marked dimples allows for either baluster-at-center or space-at-center layout and does not reflect the quantity of balusters included in the kit. **NOTE:** The space between the end baluster and the newel post cannot exceed 4".



DARK PAINT CAUTION

If you choose to paint your TimberTech PVC Statement Rail and/or Pinnacle Rail Product, TimberTech recommends the use of Exterior 100% Acrylic Latex paint. Preferably paints designed for use with PVC products. Please contact your local paint dealer for professional assistance. Due to the inherent expansion and contraction characteristics of PVC, TimberTech PVC Statement and Pinnacle Rail should only be painted colors with an LRV (light reflective value) greater than 55. Do not use darker colors due to excessive expansion/contraction, movement, warping, oil canning, distortion and will void the product warranty.

| COLOR RANGE | KEY COLORS SELECTION CRITERIA | PAINT TYPE |
|---------------------------|--|-----------------------------|
| Lighter paint colors only | Must have a light reflective value (LRV) of above 55 | Exterior 100% Acrylic Latex |







CLEANING PRODUCTS FOR TIMBERTECH PVC RAILING PRODUCTS

Cleaning TimberTech PVC Statement Rail and Pinnacle Rail is easy and fast with most major household cleaners. The cleaning solution should be applied and then rinsed off completely and wiped dry. As with any cleaning material, the cleaning solution should not be left to stand on the components for an extended period of time and should be tested on a sample piece prior to any application. Always work in a manageable area to not allow the cleaner to dry onto the railing.

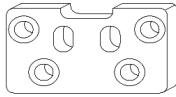
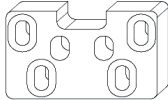
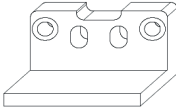
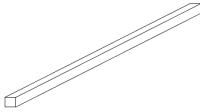

WHAT TO AVOID

Harsh cleaners with glycol ethers or ethanol type solvents and/or isopropyl alcohol are not recommended. Examples of these harmful cleaners are Goof Off®, Walmart "Great Value All Purpose Cleaner" (glycol ether), 409 General Purpose® (2- Butoxyethanol) and Greased Lightning® (glycol ether), citrus cleaners, abrasive cleaners, and solvents such as acetone, paint remover, lacquer thinner, composite deck cleaners and sodium hydro chloride based cleaners.

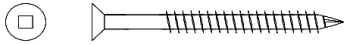
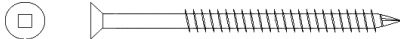
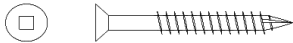
| ITEM | | QUANTITY PER KIT | |
|---|--|------------------|----|
| | | 6' | 8' |
| Rail Cap |  | 1 | 1 |
| Common Rail Used at Top & Bottom of Balusters |  | 2 | 2 |
| Upper & Lower Reinforcement |  | 2 | 2 |
| Level Rail Brackets |  | 4 | 4 |
| Stair Rail Brackets - Upper Included with Stair Rail Kits Only |  | 2 | 2 |
| Stair Rail Brackets - Lower Included with Stair Rail Kits Only |  | 2 | 2 |
| Baluster 1-1/4" Square 29-3/4" or 35-3/4" |  | 13 | 18 |
| Crush Block 1-1/4" Square x 4" |  | 1 | 2 |
| A Rail Bracket Screws #8 X 1-1/4" Flat Head Square Drive |  | 16 | 16 |
| B Rail Attachment Screws #10 X 3" Slot Hex Washer Head |  | 10 | 10 |
| C Top Rail Cap Attachment Screws #8 X 1-3/4" Flat Head Square Drive |  | 4 | 4 |
| D Baluster Screws #8 X 2-1/2" Flat Head Square Drive |  | 31 | 44 |
| E Baluster Lock Screws #8 X 1-1/2" Flat Head Square Drive |  | 13 | 18 |

LEVEL RAIL SECTION APPLICATION

1 MEASURE TO DETERMINE BALUSTER LAYOUT, CUT RAIL SECTIONS TO LENGTH

- a. Ensure newels or columns to which rail will be mounted are plumb and sturdy enough to support rail. If newel/column covers are used, ensure they have blocking at each location where railing will be attached.
- b. Measure span at top and bottom rail locations.
- c. For standard baluster spacing (with the variable spaces at the ends of each rail section), the pre-marked locations inside the top/bottom common rail can be used. Hold one section of the Top/Bottom Common Rail at the bottom of the newels, and using the pre-marked locations as a reference, determine the best end baluster spacing by either locating a baluster directly at the center of the rail section, or the mid-point between two balusters as the center of the rail section. Once the best end baluster spacing is decided, mark both ends of the rail at the newels and square cut using a miter box. The Top and Bottom Common Rail must be cut with exactly the same spacing, to ensure that the balusters will be plumb. Cut the Rail Top Cap to the required length.
- d. If equal spacing between all balusters and the newels/columns is desired, disregard section 'c' above and determine spacing based upon width and number of balusters (**NOTE:** Check local building codes for maximum spacing allowed).

2 DRILL AND ASSEMBLE RAIL/BALUSTER SECTION

- a. Using the decided upon spacing, at the center of the location for each Baluster, drill a 1/8" hole through the Top and Bottom Common Rail at the centerline.
- b. Secure each Baluster with one *baluster screw* (D) through the Top Common Rail, and one through the Bottom Common Rail. Ensure Balusters are straight and aligned and secure with one *baluster lock screw* (E) through the Bottom Common Rail (offset from center) to preclude Baluster from rotating after installation.

3 PREPARE ALUMINUM REINFORCEMENTS

- a. Cut the aluminum rail reinforcements to length, 1/4" shorter than the PVC rails.
- b. Attach a mounting bracket to both ends of each Aluminum Rail Reinforcement, using four *rail bracket screws* (A). Lubricate the threads with soap or oil to avoid binding and use a clutch type drill to avoid stripping screws.
- c. Locate crush block(s) provided to the bottom Aluminum Rail Reinforcement, with spacing no greater than 36" from the end, or between Crush Blocks.
- d. Drill a 3/16" hole through the Aluminum Rail Reinforcement, and secure each crush block using one *baluster screw* (D).
- e. Drill one additional 3/16" hole at each end of the bottom Aluminum Rail Reinforcement for drainage.

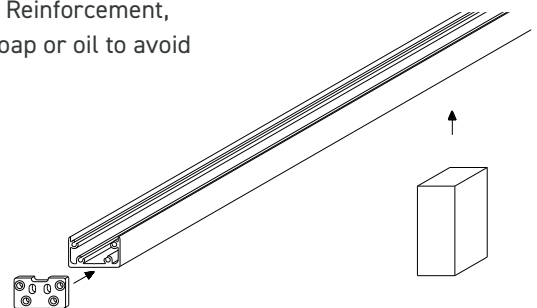

4 INSTALL RAIL

- a. Position bottom Aluminum Rail Reinforcement, with crush block(s) attached, between newels or columns, centered in newel or column face, and secure each end with two *rail attachment screws* (B).
- b. Position PVC rail/baluster assembly between newels or columns and seat fully down on bottom aluminum rail reinforcement.
- c. Seat remaining aluminum reinforcement into Top Common Rail.
- d. Ensure rail is centered on face of newel or column and secure each end with two *rail attachment screws* (B).
- e. Drill a 3/16" hole through the aluminum reinforcement over every third baluster (note: offset to avoid the screw which attaches the Baluster to the Top Common Rail) and secure the aluminum reinforcement to the rail/baluster assembly using *baluster screws* (D).
- f. Drill a 3/16" hole down through the aluminum reinforcement and the Top Common Rail between the first and second baluster at both ends and near the center of the span (all between balusters). Countersink holes from underside of Top Common Rail for a #8 Screw to ensure that screw seats flush with PVC and to prevent stripping.
- g. Apply a bead of latex caulk at the contact areas where the Rail Top Cap seats on the Top Common Rail. Seat the Rail Top Cap fully onto the Top Common Rail, and use the screws provided to attach the Rail Cap, screwing up through the underside of the Top Common Rail, be sure not to over-tighten screw to prevent stripping. **NOTE:** Screws provided for PINNACLE flat Cap Rail are *top rail attachment screws* (C).

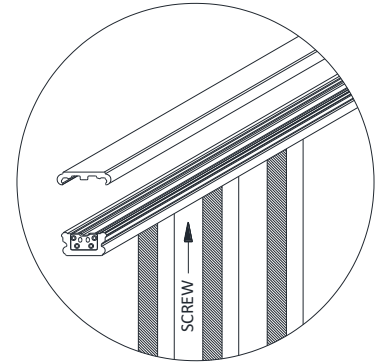

STAIR OR RAKE RAIL APPLICATION

NOTE: IBC code requires that finished stair rail heights be a minimum of 34" plumb off the nose of the tread. The standard PINNACLE 36" rail kit's balusters will typically meet these requirements provided the rail is being installed with the bottom rail elevated above the stair treads. In the event that the railing is being installed directly at or slightly above the stair tread nose, TimberTech recommends using the PINNACLE Stair/Rake Rail kit, which will meet the minimum height requirement any scenario.

1 DETERMINE ANGLE, MEASURE RAIL LENGTHS AND DETERMINE BALUSTER LAYOUT/SPACING

- a. Ensure newels or columns to which rail will be mounted are plumb and sturdy enough to support rail. If newel/column covers are used, ensure they have blocking at each location where railing will be attached.
- b. Determine and mark angle.
- c. For standard baluster spacing (with the variable spaces at the ends of each rail section), use the pre-marked locations inside the Top and Bottom Common Rail. Determine best end spacing by either locating a baluster directly at the center of the rail section, or the mid-point between two balusters as the center of the rail section. Once Baluster spacing is determined, cut end(s) of Top and Bottom Common Rail to angle and length. Note: do not cut Rail Top Cap until section is assembled and secured at all 4 mounting points.
- d. If equal spacing between all balusters and newels/columns is desired, disregard Section c above and determine spacing based upon width and number of balusters (**NOTE:** Check local building codes for maximum spacing allowed).

2 ASSEMBLE RAIL/BALUSTER SECTION

- a. Trim Balusters to required length and angle.
- b. Using the decided upon spacing, at the center of the location for each Baluster, drill a 1/8" hole through the Bottom Common Rail at the centerline, at the angle of the Baluster attachment. Repeat this for process for the Top Common Rail, using the same spacing.
- c. Secure each baluster with one *baluster screw* (D) through the Top Common Rail, and one through the Bottom Common Rail. Ensure balusters are straight and aligned and secure with one *baluster lock screw* (E) through the bottom rail (offset from center) to prevent the baluster from rotating after installation.

3 PREPARE ALUMINUM REINFORCEMENTS

- a. Attach a Lower Stair Bracket (90-degree bend) using two *rail bracket screws* (A) to the lower end of each reinforcement. Lubricate the threads with soap or oil to avoid binding and use a clutch type drill to avoid stripping screws. **NOTE:** Do not cut this end of the reinforcement to the rake angle.

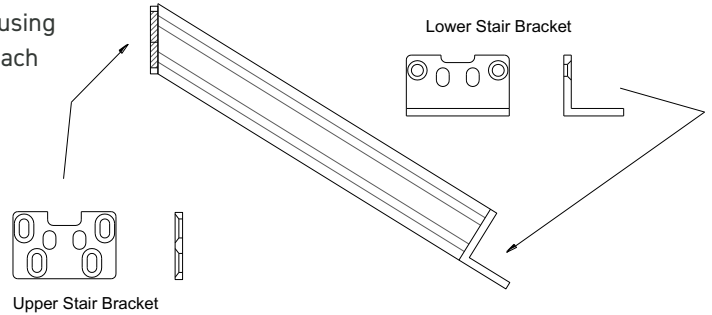

- b. Measure and cut the upper end of both reinforcements to the rail angle determined in Step 1, include the protruding portion of the lower bracket as part of the total length. Attach an upper stair bracket to the angle cut end of the top rail reinforcement, with the bracket flush with the top of the reinforcement, using four *rail bracket screws* (A). Attach an upper stair bracket to the angle cut end of the bottom rail reinforcement, with the bracket flush with the bottom of the reinforcement, using four *rail bracket screws* (A). Lubricate the threads with soap or oil to avoid binding and use a clutch type drill to avoid stripping screws.

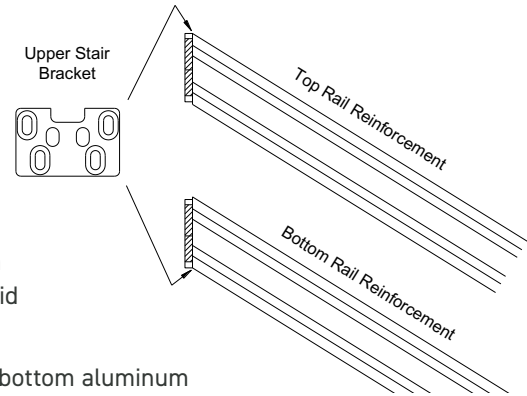

- c. Cut one end of Crush Block to angle of rail and locate to the bottom aluminum rail reinforcement, with spacing no greater than 32" from the end, or between Crush Blocks. Ensure that the Crush Block(s) will be located on a stair tread.
- d. Drill a 3/16" hole through the Aluminum Rail Reinforcement, and secure each Crush Block using one *baluster screw* (D).

4 INSTALL RAIL

- Position bottom aluminum rail reinforcement, with crush block(s) attached, between newels or columns, centered on newel or column face, and secure each end with two *rail attachment screws* (B).
- Position PVC rail/baluster assembly between newels or columns and seat fully down on bottom aluminum rail reinforcement.
- Seat remaining aluminum reinforcement into Top Common Rail.
- Ensure rail is centered on face of newel or column and secure each end with two 4" *rail attachment screws* (C).
- Drill a 3/16" hole through the aluminum reinforcement over every third baluster (**NOTE:** Offset to avoid the screw which is into the top of each baluster) and secure the aluminum reinforcement to the rail/baluster assembly using *baluster screws* (D).
- Measure and cut Top Cap to required angle and length. Drill a 3/16" hole down through the aluminum reinforcement and the Top Common Rail between the first and second baluster at both ends and near the center of the span (all between balusters). Countersink holes from underside of Top Common Rail for a #8 Screw to ensure that screw seats flush with PVC and to prevent stripping.
- Apply a bead of latex caulk at the contact areas where the Rail Top Cap seats on the Top Common Rail. Seat the Rail Cap fully onto the Top Common Rail, and use the screws provided to attach Rail Cap, screwing up through the underside of the Top Common Rail, be sure not to over-tighten screw to prevent stripping. **NOTE:** Screws provided for PINNACLE flat Cap Rail are *top rail attachment screws* (C).

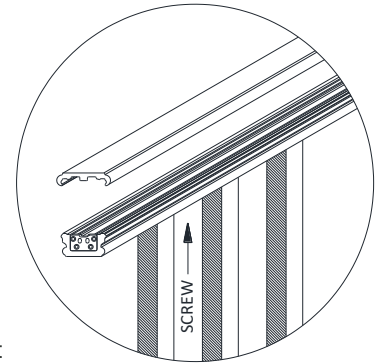

SPECIAL APPLICATIONS/SITUATIONS

NOTE: the following situations are not CCRR compliant.

RAIL TO NEWEL CONNECTIONS AT AN ANGLE

This method can be used for angled rail connections to newels, up to a 45 degree angle.

- Determine length and angles for connections to newels at both ends. Cut PVC common rails to fit, remembering orientation of common rail before cutting (one up, one down). Ensure that the centerline of the rail is aligned with the center of the newel cover.
- Measure the short side(s) of the reinforcement slot in the common rail and cut the aluminum reinforcement at a 90-degree angle, 3/8" shorter.
- Attach standard level-rail mounting brackets to the reinforcement (see Section 3b in main instructions).

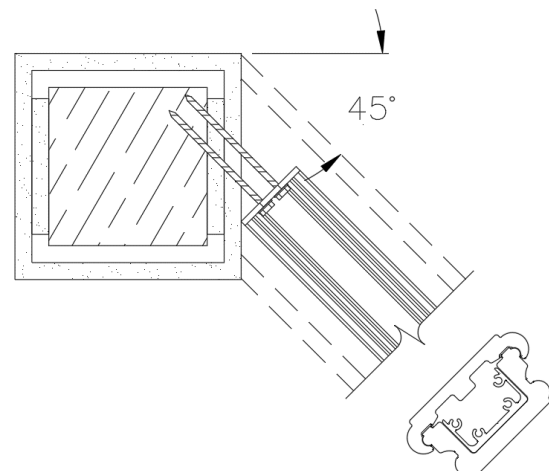

SPECIAL APPLICATIONS/SITUATIONS *(continued)*

RAIL TO NEWEL CONNECTIONS AT AN ANGLE *(continued)*

A filler block must be used in the open triangular space between the bracket and the newel face. Lay the reinforcement w/bracket attached into the common rail and determine size/angle required. Rip a spare baluster to 3/4" thickness, and cut to fit.

- Attach spacer to newel face using stainless steel screws and PVC glue. (Place screws at the lower portion of the spacer, to avoid the screws that will attach the bracket to the newel, which will go through the upper portion.)
- Position and attach reinforcements to newels as in Sections 4a and 4d in the main instructions. Insure that attachment screws penetrate into structural newel.
- This method is also used for radius rail attachment to newels, but using the radius rail brackets.

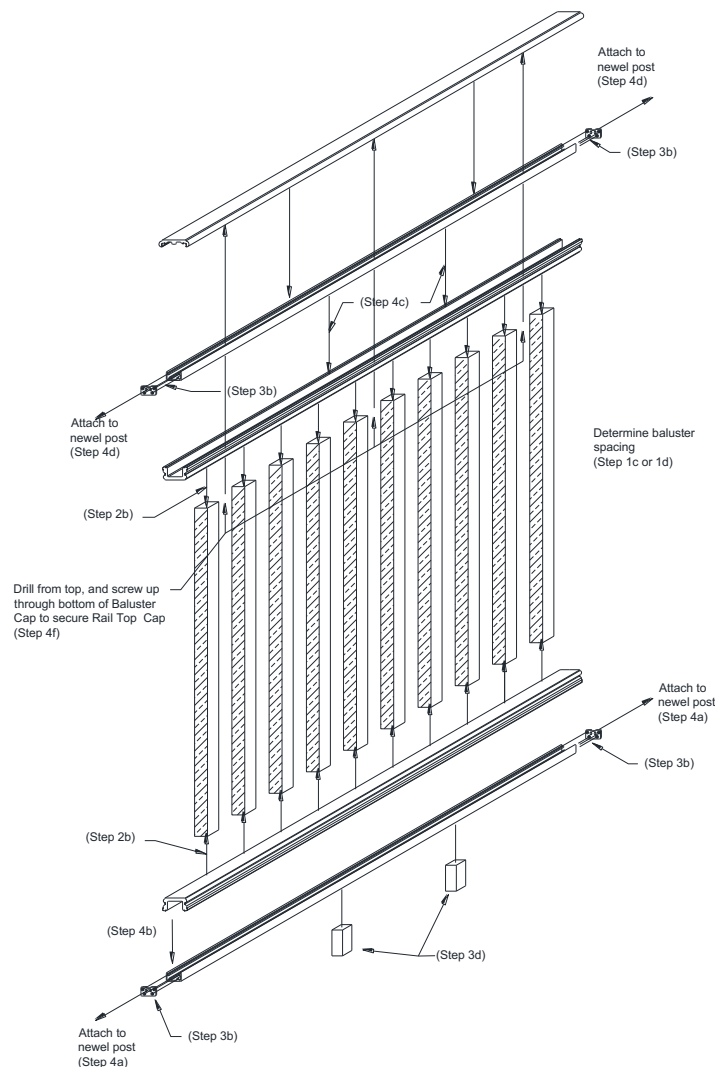
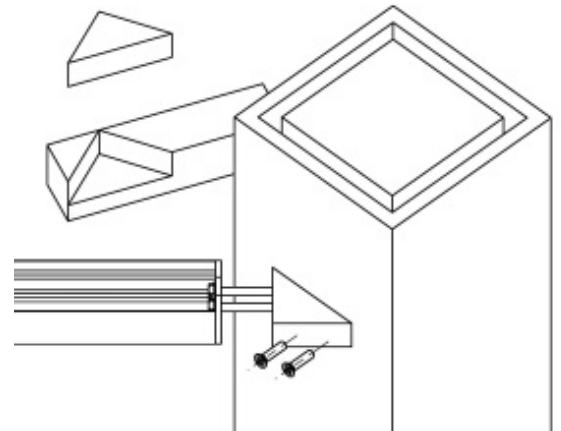



AZEK Building Products
1330 W Fulton Market, Suite #350
Chicago, IL 60607

©2022 AZEK Building Products. All Rights Reserved.

